



# Temperature Measurement eBook

## Volume 1

*RTD, Pt100, temperature sensors  
and probes, includes selection guide.*

[www.omega.co.uk](http://www.omega.co.uk)

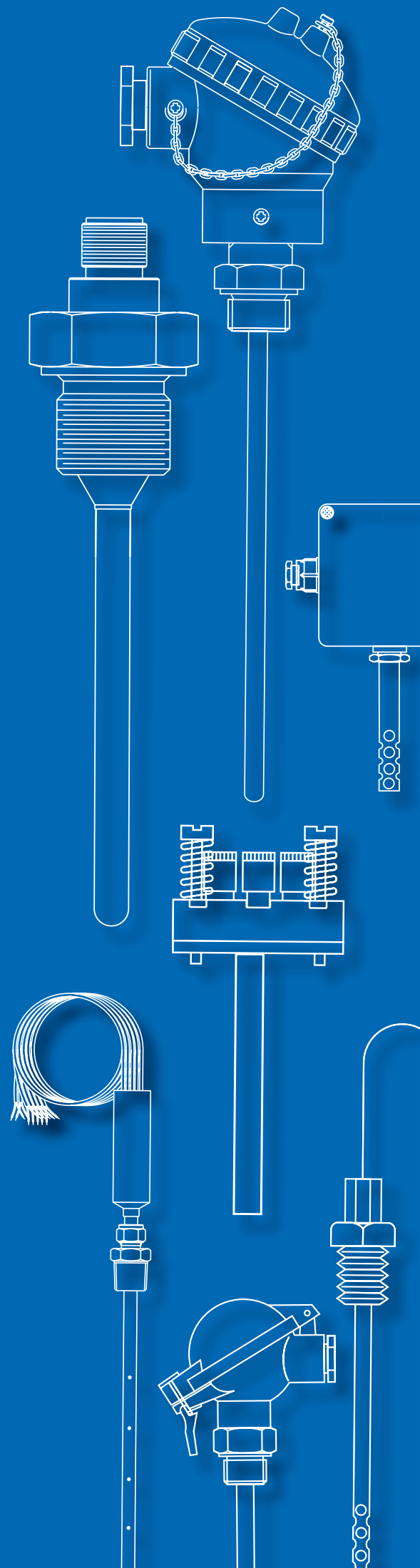

## ***About Us***

Precision Manufacturing	3
Calibration Facility	4

## ***What are RTDs***

Why use them and how they work	5-7
--------------------------------	-----

## ***M12 RTD Sensors***

PR-26 RTD Probes	9
PR-25CU Copper Tipped Sensors	10
PR-21 Sensor	11
PR-22 RTD Probe	12
TX-M12 Probe Head	12
PR-31 High Temperature	13
M12-TXSS	13
PR-25AP Air RTD Sensors	14
M12C Series	15

## ***RTD Heads***

Pt100 Probe Heads	16
Pt100 Probe Heads	17
T3 Head Probes	18
Terminal Block Pt100 Probe	19

## ***Pt100 Probe Elements***

Pt100-BSP	19
EWSE Wall Mount Probe	20
PRMAG RTD Magnet Sensor	20
PR-850 Sensor with M4 Thread	21
PR-11 RTD with Braided Cable	22
P-Ultra RTD with Air Stream	22
PR-10 Low Cost RTD	23
PR-16 RTD with Flexible Handle	23

## ***Wire and Patch RTD Sensors***

SA2 Silicone Patch Sensor	24
Surface Mount RTD	24
Thin Film RTD Element	25
Hermetically Sealed RTD	25

## ***RTD with DIN Connectors***

PR-24 Series with Micro-DIN Connection	26
----------------------------------------	----

## ***RTD Wire Guide***

Wire and Extension Guide for RTDs	27
-----------------------------------	----

## ***RTD/Pt100 Selection Guide***

Product Summery	28-31
-----------------	-------

## ***Contact Us***

Contacts and Useful Information	32
---------------------------------	----

## Precision Manufacturing

OMEGA gives customers the widest choice of standard & bespoke products. Grouped into product lines and technologies including temperature, industrial heaters, pressure, flow, data acquisition, automation, laboratory and environmental control, we truly are your single source provider for all your product needs. We can provide custom designs and assemblies, and we offer volume manufacturing for OEM needs in temperature, pressure and electronic controls.

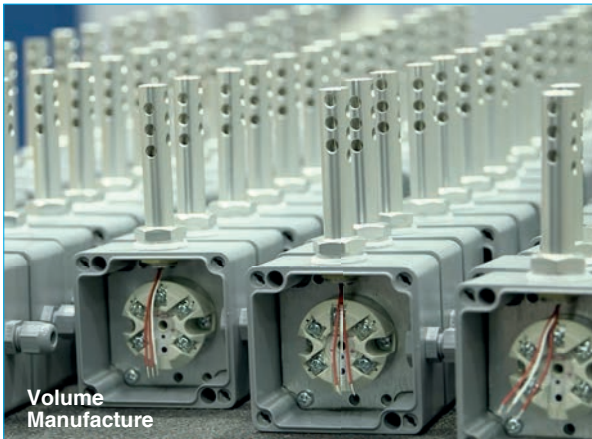

Volume Manufacture

## Standard and Bespoke Products

All product designs are tested and perfected in our state-of-the-art facility. The testing that takes place here assures that you receive the best products for your applications. Once an OMEGA product design is perfected and tested, stock production takes place at our Manchester manufacturing facility.



Manchester Manufacturing HQ.

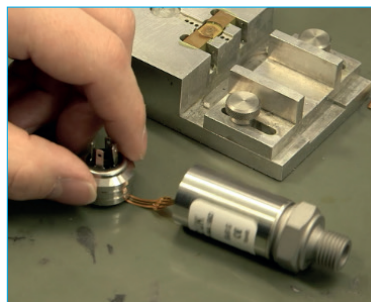

Our Manchester HQ has over 45,000 sq ft. of operations and a skilled work force to manufacture your products. Our dedicated pressure facility produces the

highest quality transducers, transmitters and custom order products. Our temperature department specialises in high precision assembly capable of manufacturing exotic probes, MI thermocouple probes, connectors, RTD sensors, wire and patch sensors, M12 sensors, and custom designed solutions.

## Custom Design Solutions

Whether you need a simple modification of a standard product or complete customised system engineered, OMEGA can accommodate your special request.



Unlike many online stores and distributors OMEGA has the capability to design and manufacture probes - all compliant to CE standards.

Each OMEGA product goes through a quality control process that ensures all dispatched items are of the highest standard.

## Calibration Services

OMEGA is constantly striving to find new ways to increase the level of service available to our customers. To this end, OMEGA continues to expand the range of calibration services available, offering a broad selection of standards for use in calibrating temperature, infrared, humidity, pressure, flow, and force products. By maintaining these standards in-house, we can ensure fast turnaround time on calibrations.



Our calibration laboratory is able to calibrate a wide variety of testers ranging from electrical meters such as multimeters and clamp meters to specific testers such as barometers, vacuum gauges, anemometers, digital thermometers and much more.

### We calibrate -30 °C to +1200 °C

Our specialist facilities can calibrate your:

- Thermocouples ( -30 °C to +1200 °C)
- RTDs (-30 °C to 300 °C)
- Thermistors (-30 °C to 300 °C)
- Infrared Devices ( -18 °C to +400 °C)

Interested in our calibration services? Here is a list of areas we cover:

- Temperature, Infrared
- Pressure, Strain & Force
- Electrical, Voltmeters, Multimeters
- Airspeed, Anemometers
- Humidity

And we offer **ISO certified calibration traceable to UK or NIST standards.**

From food production to pharmaceuticals, many industry bodies require system calibration to ensure measurement integrity. With state-of-the-art reference equipment, OMEGA provides calibration that is fully traceable back to a wide range of standards.

All calibrations are performed by our technicians. Contact OMEGA's Customer Service Department (0161 777 2225) to discuss your specific calibration requirements.



### After Sales Care

Omega has technical Engineering Support for both pre and post sales product usage. They are available to help you with any in-depth application need regarding Omega products you are considering purchasing. After purchase they can also help you with questions regarding installation and use of our products.

Call **0161 777 2225** to speak with an expert.

## What are RTD Sensors? Why Use Them? How Do They Work?

### What is an RTD?

Resistance Temperature Detectors (RTDs) are temperature sensors that contain a resistor that changes resistance value as its temperature changes. They have been used for many years to measure temperature in laboratory and industrial processes, and have developed a reputation for accuracy, repeatability, and stability.

### Why use an RTD instead of a thermocouple or thermistor sensor?

Each type of temperature sensor has a particular set of conditions for which it is best suited. RTDs offer several advantages:

- A wide temperature range (approximately -200 to 850°C)
- Good accuracy (better than thermocouples)
- Good interchangeability
- Long-term stability

With a temperature range up to 850°C, RTDs can be used in all but the highest-temperature industrial processes. When made using metals such as platinum, they are very stable and are not affected by corrosion or oxidation. Other materials such as nickel, copper, and nickel-iron alloy have also been used for RTDs. However, these materials are not commonly used since they have lower temperature capabilities and are not as stable or repeatable as platinum.

### RTD standards

There are two standards for platinum RTDs: the European standard (also known as the DIN or IEC standard) and the American standard.

The **European standard** is considered the world-wide standard for platinum RTDs. This standard, DIN/IEC 60751 (or simply IEC751), requires the RTD to have an electrical resistance of 100.00 Ω at 0°C and a temperature coefficient of resistance (TCR) of 0.00385 Ω/Ω/°C between 0 and 100°C.

There are two resistance tolerances specified in DIN/IEC751:

Class A =  $\pm(0.15 + 0.002 \cdot t)$ °C or 100.00 ±0.06 Ω at 0°C  
 Class B =  $\pm(0.3 + 0.005 \cdot t)$ °C or 100.00 ±0.12 Ω at 0°C

Two resistance tolerances used in industry are:

$\frac{1}{3}$  DIN =  $\pm\frac{1}{3} \cdot (0.3 + 0.005 \cdot t)$ °C or 100.00 ±0.10 Ω at 0°C  
 $\frac{1}{10}$  DIN =  $\pm\frac{1}{10} \cdot (0.3 + 0.005 \cdot t)$ °C or 100.00 ±0.03 Ω at 0°C

The combination of resistance tolerance and temperature coefficient define the resistance vs. temperature characteristics for the RTD sensor. The larger the element tolerance, the more the sensor will deviate from a generalised curve, and the

more variation there will be from sensor to sensor (interchangeability).

OMEGA uses a resistance vs. temperature curve from -200 to 850°C with resistance values given for every degree Celsius. The following interchangeability table shows how the tolerance and temperature coefficient affect the indicated temperature of the sensor in degrees Celsius:

Interchangeability in °C				
Temp °C	Class B	Class A	$\frac{1}{3}$ DIN	$\frac{1}{10}$ DIN
-200	1.30	—	—	—
-100	0.80	—	—	—
-50	0.55	0.25	0.18	—
0	0.30	0.15	0.10	0.03
100	0.80	0.35	0.27	0.08
200	1.30	0.55	0.43	—
250	1.55	0.65	0.52	—
300	1.80	0.75	—	—
350	2.05	0.85	—	—
400	2.30	0.95	—	—
450	2.55	1.05	—	—
500	2.80	—	—	—
600	3.30	—	—	—

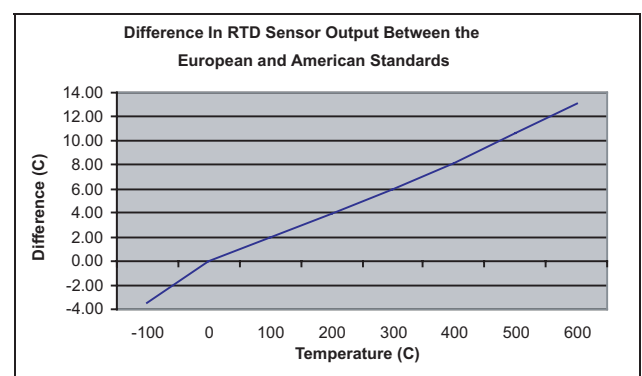

### Other resistance value options

RTD elements can also be purchased with resistances of 200, 500, 1000, and 2000 Ω at 0°C. These RTDs have the same temperature coefficients as previously described, but because of their higher resistances at 0°C, they provide more resistance change per degree, allowing for greater resolution.

# What are RTD Sensors? Why Use Them? How Do They Work?

## RTD Element Construction

Platinum RTD elements are available in two types of constructions: thin film and wire wound.

### Thin Film

Thin-film RTD elements are produced by depositing a thin layer of platinum onto a substrate. A pattern is then created that provides an electrical circuit that is trimmed to provide a specific resistance. Lead wires are then attached and the element coated to protect the platinum film and wire connections.

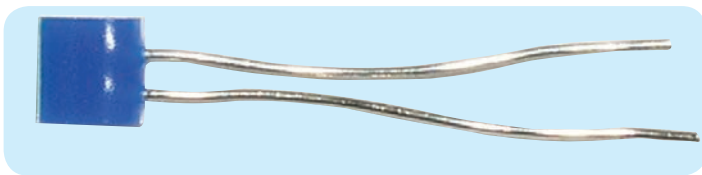

OMEGA's F2020, 100 Ω, Class "A" thin-film element

Thin film elements are available in European standard ( $0.00385 \Omega/\Omega/^\circ\text{C}$ ), and in a special version, used primarily in the appliance industry, that has a temperature coefficient of  $0.00375 \Omega/\Omega/^\circ\text{C}$ .

### Wire Wound

RTD elements also come in wire-wound constructions. There are two types of wire-wound elements: those with coils of wire packed inside a ceramic or glass tube (the most commonly used wire-wound construction), and those wound around a glass or ceramic core and covered with additional glass or ceramic material (used in more specialised applications).



Typical wire-wound RTD element

### Wiring Arrangement

In order to measure temperature, the RTD element must be connected to some sort of monitoring or control equipment. Since the temperature measurement is based on the element resistance, any other resistance (lead wire resistance, connections, etc.) added to the circuit will result in measurement error.

The four basic wiring methods are shown below.

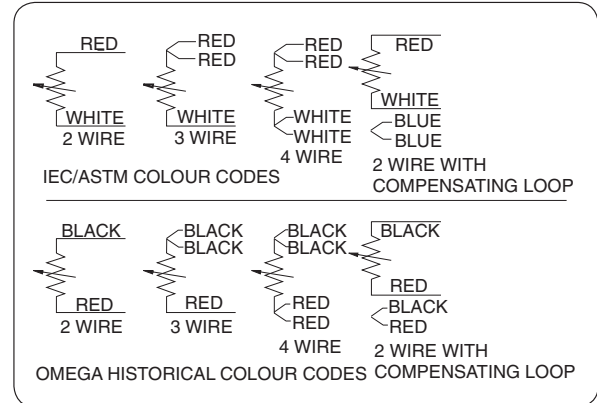

Except for the 2-wire configuration, each of the above wiring arrangements allows the monitoring or control equipment to factor out the unwanted lead wire resistance and other resistances that occur in the circuit.

Sensors using the 3-wire construction are the most common design, found in industrial process and monitoring applications. The lead wire resistance is factored out as long as all of the lead wires have the same resistance; otherwise, errors can result.

Sensors using the 4-wire construction are found in laboratories and other applications where very precise measurements are needed.

### Wire Materials

When specifying the lead wire materials, care should be taken to select the right lead wires for the temperature and environment the sensor will be exposed to in service. Below is a table listing the capabilities of the three most popular constructions:

Lead Wire Materials			
Insulation	Temperature Range	Abrasion Resistance	Water Submersion
PVC	-40 to 105°C	Good	Good
PFA	-267 to 260°C	Excellent	Excellent
Fibreglass	-73 to 482°C	Poor	Poor

### Configuration

Once the RTD element, wire arrangement, and wire construction are selected, the physical construction of the sensor needs to be considered. The final sensor configuration will depend upon the application.

Measuring the temperature of a liquid, a surface, or a gas stream requires different sensor configurations.

## What are RTD Sensors? Why Use Them? How Do They Work?

### Liquid Measurements

Probe-type sensor styles are normally used for measuring liquids. They can be as simple as our general purpose PR-10 and PR-11 constructions, or as involved as our PR-12, 14, 18, or 19—with connection heads and transmitters. A popular choice is the quick-disconnect sensor. This can be used as is, with compression fittings for flexible installation, or with our PRS plastic handle for a handheld probe.

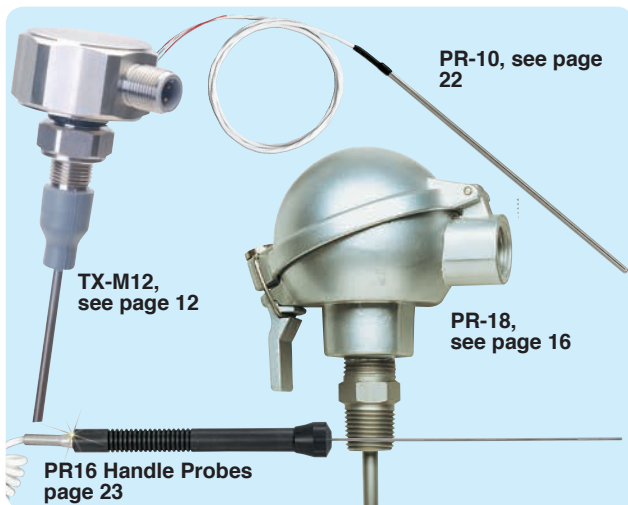

When measuring the temperature of harsh environments such as plating baths or highly pressurised systems, sensors can be coated with a material like PFA, or they can be housed in a thermowell to protect the sensor from extreme conditions. Speak to our application engineers if you have any special measurement challenges.

### Air and Gas Stream Measurements

Air and gas stream measurements are a challenge because the rate of transfer of temperature from the fluid to the sensor is slower than for liquids. Therefore, sensors specifically designed for use in air or gas place the sensing element as close to the media as possible.

OMEGA's RTD-805 and 806 sensors allow the sensing element to be nearly in direct contact with the air stream. With a housing design containing slots that allow the air to flow past the element, this construction is very popular in measuring air temperature in laboratories, clean rooms, and other locations.



### Surface Temperature Measurements

Surface measurements can be one of the most difficult to make accurately. There are a wide variety of styles to choose from, depending on how you want to attach the sensor, how sensitive to changes in temperature the sensor has to be, and whether the installation will be permanent.

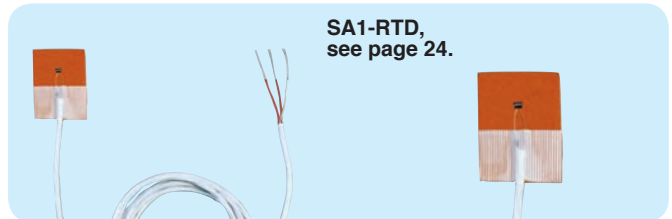

The most accurate and fastest-responding surface RTD is our SA1-RTD sensor. When applied to a surface, it becomes virtually a part of the surface it is measuring.

Surface sensors can also be bolted, screwed, glued, or cemented into place. The RTD-830 has a pre-machined hole in the housing to allow for

easy installation with a screw. The RTD-850 has a housing with threaded tip that allows it to be installed into a standard M4 threaded hole.

This RTD is handy for measuring the temperature of heat sinks or structures where screw holes may already exist.

### Element and Wire Assemblies

Finally, if a simple RTD sensor with element and leads is all you need, or you would like to build up your own sensor, there are a wide variety of element and cable configurations to choose from. Our element and wire assemblies can also be cemented directly to a structure. These sensors can be manufactured with any of OMEGA's RTD elements and can include PFA, fibreglass, or bare lead wires to suit your application. We encourage you to call our application engineers to tap into these vast resources. If the product you need is not on the shelf, in most cases we can turn it around quickly to meet your needs.

<b><i>M12 RTD Sensors</i></b> .....	
<b><i>PR-26 RTD Probes</i></b>	<b>9</b>
<b><i>PR-25CU Copper Tipped Sensors</i></b>	<b>10</b>
<b><i>PR-21 Sensor</i></b>	<b>11</b>
<b><i>PR-22 RTD Probe</i></b>	<b>12</b>
<b><i>TX-M12 Probe Head</i></b>	<b>12</b>
<b><i>PR-31 High Temperature</i></b>	<b>13</b>
<b><i>M12-TXSS</i></b>	<b>13</b>
<b><i>PR-25AP Air RTD Sensors</i></b>	<b>14</b>
<b><i>M12C Series</i></b>	<b>15</b>
<b><i>RTD Heads</i></b> .....	
<b><i>Miniature, Sub-Miniature, Hinged Heads</i></b>	<b>16</b>
<b><i>Cast Iron and Hygienic Heads</i></b>	<b>17</b>
<b><i>T3 Head Probes Series</i></b>	<b>18</b>
<b><i>Terminal Block Pt100 Probe</i></b>	<b>19</b>
<b><i>Industrial Probes</i></b> .....	
<b><i>Pt100-BSP Pipe Plug</i></b>	<b>19</b>
<b><i>EWSE Wall Mount Probe</i></b>	<b>20</b>
<b><i>PR-MAG RTD Magnet Sensor</i></b>	<b>20</b>
<b><i>PR-850 Sensor with M4 Thread</i></b>	<b>21</b>
<b><i>PR-11 RTD with Braided Cable</i></b>	<b>22</b>
<b><i>P-Ultra RTD with Air Stream</i></b>	<b>22</b>
<b><i>PR-10 Low Cost RTD</i></b>	<b>23</b>
<b><i>PR-16 RTD with Flexible Handle</i></b>	<b>23</b>
<b><i>Wire and Patch RTD Sensors</i></b> .....	
<b><i>SA2 Silicone Patch Sensor</i></b>	<b>24</b>
<b><i>Surface Mount RTD</i></b>	<b>24</b>
<b><i>Thin Film RTD Element</i></b>	<b>25</b>
<b><i>Hermetically Sealed RTD</i></b>	<b>25</b>
<b><i>PR-24 Series with Micro-DIN Connection</i></b>	<b>26</b>
<b><i>Wire and Extension Guide for RTDs</i></b> .....	<b>27</b>
<b><i>Product Summery</i></b> .....	<b>28-31</b>
<b><i>Contact us</i></b> .....	<b>32</b>



**Vibration Tested RTD Probes with M12 Connections**  
**Fast connection, ideal for test and measurement applications**

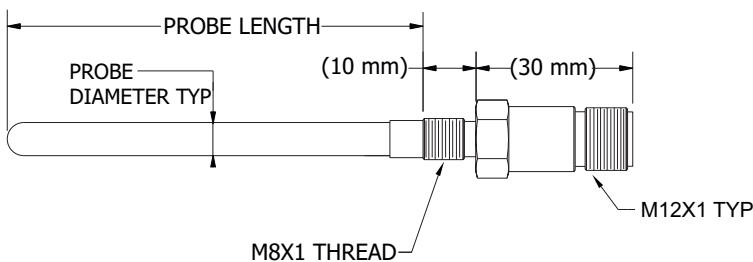
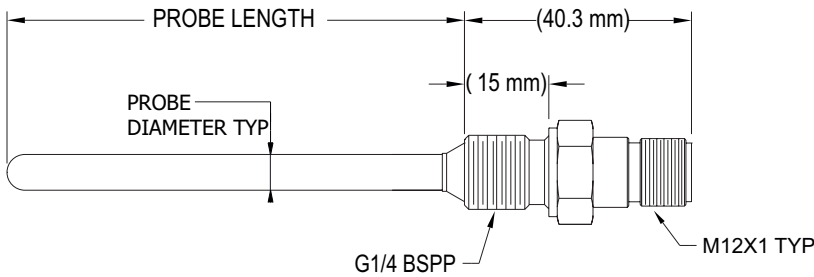
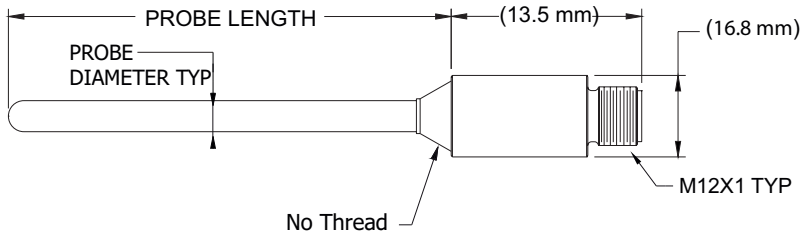
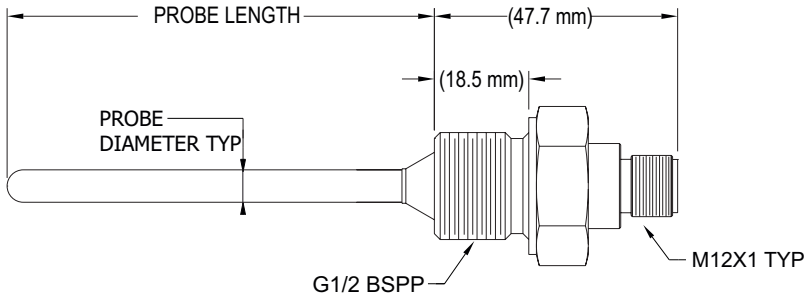

**PR-26 Options**

**Mounting Thread Choose from:**

- None
- M8x1
- M10x1
- G1/2 BSPP
- G1/4 BSPP

**Element Choose from:**

- Pt100 Class A
- Pt1000 Class B

**Sheath Diameter Choose from:**

- 3mm Diameter
- 6mm Diameter

**Length Any Length Available:**

- 150mm
- 250mm
- 350mm
- etc.....

**All measurements in mm**

The PR-26 series RTD probes are ideal for process environments with vibration and high temperature conditions. The M12 connector provides a secure, reliable, and fast connection. Factory automation, packaging, food and beverage, pharmaceutical, automobile and many other manufacturers have standardised on the M12 connection.

- Operating temperature range:  
 -50 to 500°C sensing end,  
 -50 to 250°C at connector
- Class A, Pt100 or Pt1000 4-wire platinum RTD elements per IEC60751 standard
- Bendable probes using a minimum suggested bend radius of 2x the probe diameter

## Fast Response Copper Tip RTD Sensor

Element located inside copper tip for improved thermal response



**PR-25CU Series**

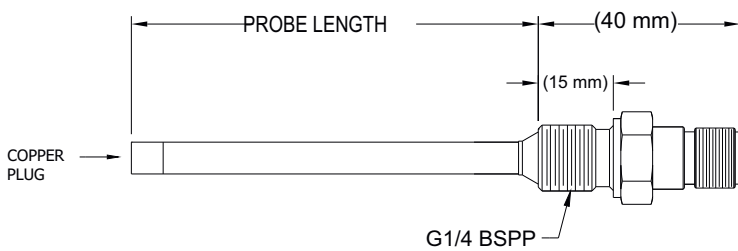
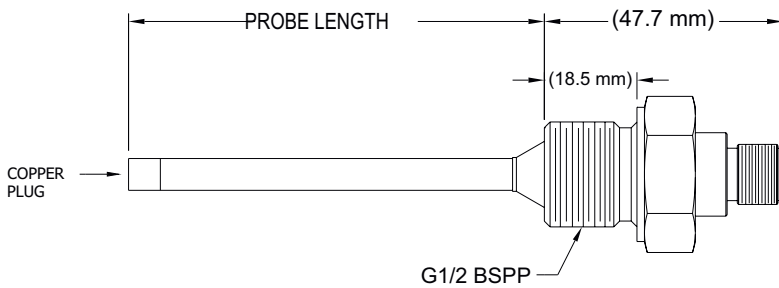
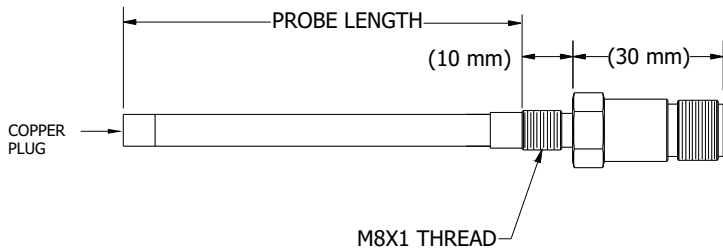
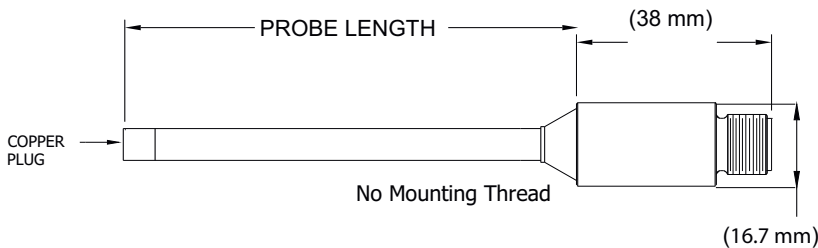

All measurements in mm

### PR-25CU Options

**Mounting Thread** Choose from:

- None
- M8x1
- M10x1
- G1/2 BSPP
- G1/4 BSPP

**RTD** Choose from:

- 100 OHM
- 1000 OHM

**Element** Choose from:

- Pt100 Class A
- Pt1000 Class B

**Sheath Diameter** Choose from:

- 4.5mm Diameter
- 6mm Diameter

**Length** Any Length Available.

Our PR-25CU Copper Tipped RTD Probe combines the ease of use and robustness of our PR-21 RTD and adds a copper tip for improved response time. When trying to measure the temperature of objects like bearings and motors where contact is limited, the copper tip provides improved sensitivity. Copper tipped sensors can provide improved response and accuracy over standard immersion probes.

- Operating temperature range:  
-50 to 250°C sensing end,  
-50 to 85°C at connector
- Response time: 4 seconds for 63.2%,  
3.25 seconds for 50%, 7.5 seconds for 90%  
[water at 0.91 m (3')/second]
- Non-threaded version can be used with  
M12-handle for hand-held use

**PT100 RTD Sensor with M12 Connector  
Can be used in any 2, 3 or 4-wire application**



**PR-21 Series**

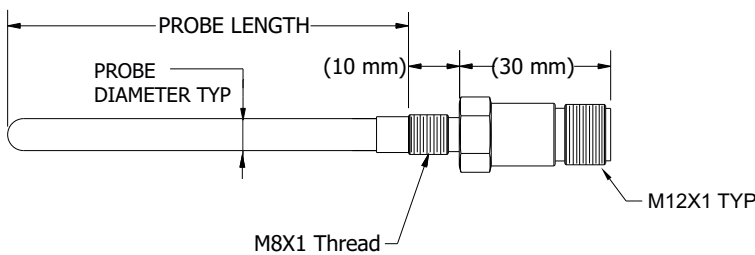
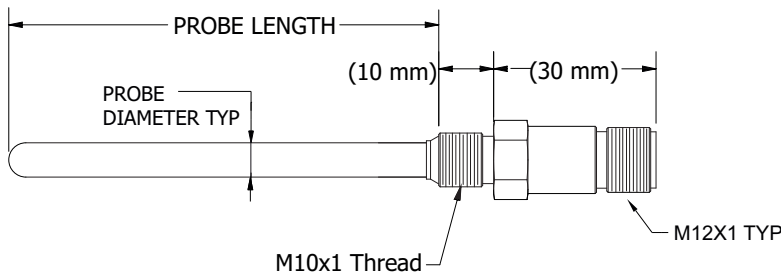
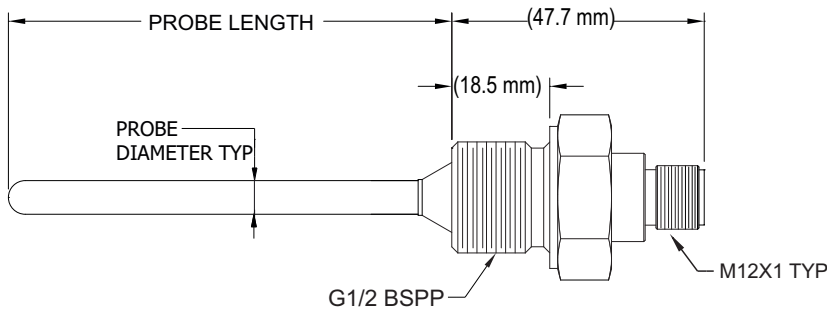
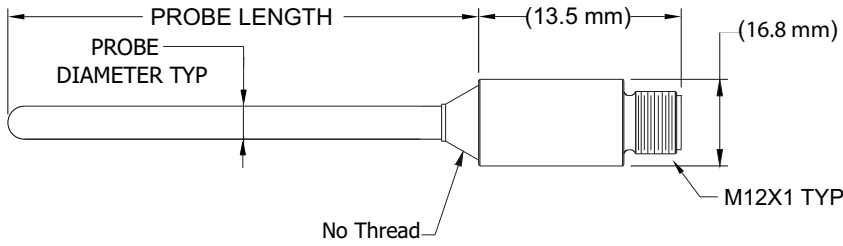

**All measurements in mm**

**PR-21 Options**

**Mounting Thread Choose from:**

- None
- M8x1
- M10x1
- G1/2 BSPP
- G1/4 BSPP

**Element Choose from:**

- Pt100 Class A
- Pt1000 Class A

**Sheath Diameter Choose from:**

- 3mm Diameter
- 6mm Diameter

**Length Any Length Available:**

- 150mm
- 250mm
- 350mm
- etc.....

The PR-21 series RTD probes are ideal installed directly into your process using a variety of standard mounting threads. PR-21 RTD sensors are made with 316L Stainless Steel probes welded to 316L Stainless Steel housings for strength and corrosion resistance. The sensors include a 4-pin, M12 A-Coded male connector for easy connection to patch cables or extension cables.

- Operating temperature range: -50 to 250°C sensing end, 85°C max at connector end
- Pt100 or Pt1000 Class A, 4-Wire platinum RTD elements per IEC60751 standard
- Fast response time (3.5 Seconds or less 63% response in water)

## Pt100 RTD Probes with M12 Moulded Connectors

Can be used in any 2-wire, 3-wire or 4-wire measurement systems

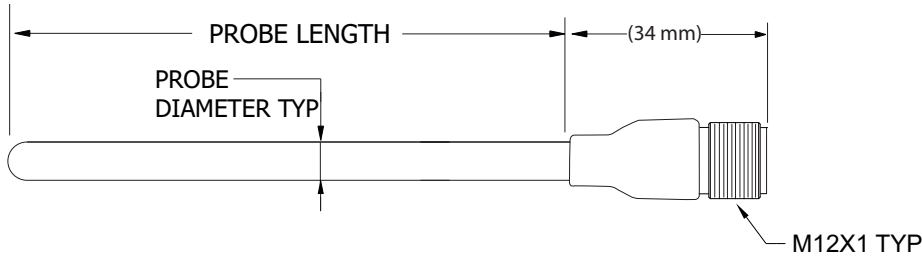

### PR-22 Series

All measurements in mm

Omega's PR-22 RTD sensor contains an RTD element that meets the resistance vs. temperature requirements of IEC 60751 making it compatible with most of the RTD capable measuring products on the market today. With an M12 connector that is pre-wired with a 4-wire connection, it can be used in any 2-wire, 3-wire or 4-wire measurement system. Simply use the number of wires needed for your application.

- Operating Temperature Range:  
-30 to 350°C (Class A)  
-50 to 500°C (Class B)
- Temperature Range  
(Connector End): -50 to 90°C
- Standard Sheath Diameters of 2, 3 and 6 mm

## Mini Pt100/1000 Temperature Transmitter With M12 connection

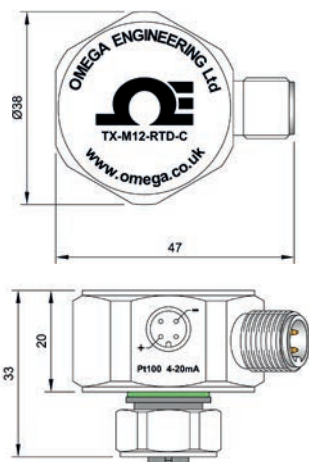

M12C-SIL-4-S-F-1.5,  
Silicone Extension Cable

PR-22 Series Probe



### TX-M12-RTD

All measurements in mm

Omega's TXM12 series transmitters offer improved performance over conventional in-head transmitters yet are a fraction of their size and weight. Integral M12 connectors maintain IP67 protection and connection integrity whilst allowing for a quick and simple change of sensor. Two models are available with either 4-20mA or 0-10Vdc output.

- Easily scaled using the optional USB interface & free software
- M12 connectors for fast connection of sensors & instrumentation
- Operating temperature range:  
-40 to +85°C ambient operating temperature  
-200 to +850°C measurement range

## RTD Probes with High Temperature Molded M12 Connector Bendable and vibration resistant

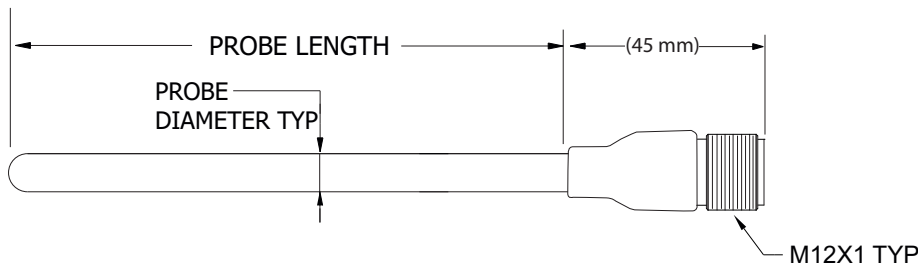

**PR-31 Series**

All measurements in mm

The PR-31 series RTD temperature sensors feature a high temperature connector for application environments of up to 260°C. They are constructed with our mineral insulated cable to offer the option of bending the probe in the field.

The PR-31 series are ideal temperature probes for the automation, food, beverage, chemical and industrial markets.

- Operating Temperature Range:  
-50 to 500°C Sensing End,  
-50 to 260°C at Connector
- Class A, Pt100 or Pt1000 4-Wire Platinum RTD Elements per IEC60751 Standard
- Bendable Probes Using a Minimum Suggested Bend Radius of 2x Probe Diameter

## M12 Stainless Steel RTD Temperature Transmitters Ideal for areas with space limitations

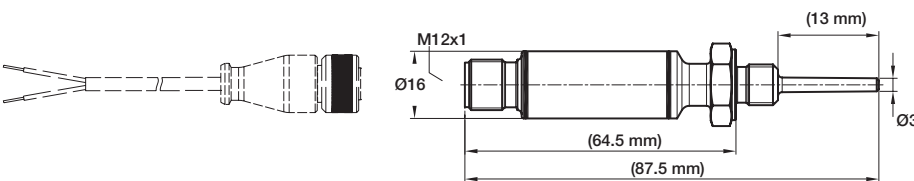

**M12TXSS Series**

All measurements in mm

RTD 100 Ω sensor with built-in transmitter is programmable by a computer. The configuration kit required for programming is M12TX-CONFIG. This unique probe is ideal for areas with space limitations where traditional head connections are too large to fit. The M12 thread design offers a secure industrial connection.

- Programmable transmitter
- 4 to 20 mA output = 0 to 100°C default setting
- -50 to 120°C full programmable range

# Air Temperature RTD Probe with M12 Connector

## Ultra-precise air measurement RTD sensors

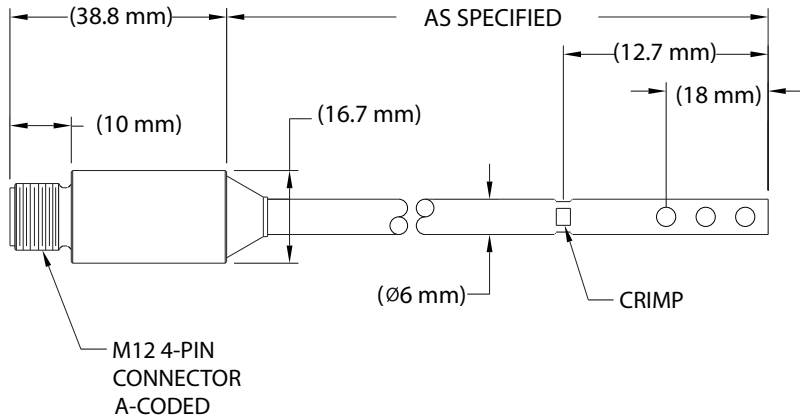

**PR-25AP Series**

### BSPP Thread Options

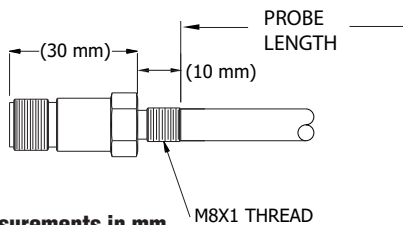
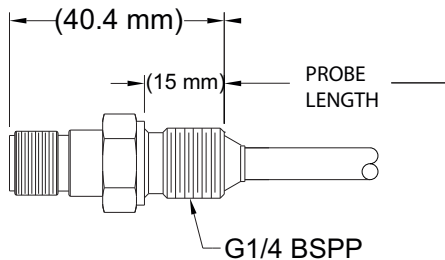
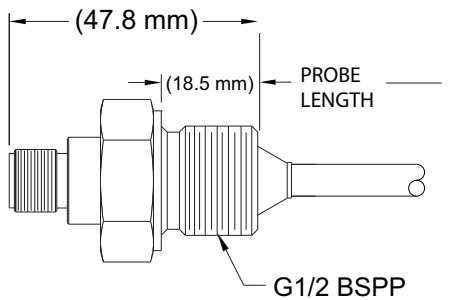

All measurements in mm

### PR-25AP Options

**Mounting Thread** *Choose from:*

- None
- M8x1
- M10x1
- G1/2 BSPP
- G1/4 BSPP

**Accuracy** *Choose from:*

- Class A
- Class AA
- 1/10 DIN

**Standard Sheath Diameter:**

6mm Diameter

**Sheath Length:**

- 150mm
- 300mm
- 450mm

*Custom Lengths Available.*

Our PR-25AP RTD Air Probe combines the availability of the high accuracy sensor options found in our Ultra-Precise RTD probes with the convenience and reliability of our M12 enabled PR-21 probes. The PR-25AP RTD is also designed to provide a barrier to airflow between the air stream and the ambient conditions that has been tested to 400 psi with no leakage.

- Operating temperature range: -100 to 250°C
- Probe will withstand 400 psi (27.6 bar) differential pressure between air-stream and ambient Conditions
- M12, 4-Pin, A-coded plug connector for easy installation

**M12 Moulded Extension Cables**  
**M12C Series extension cables**



**M12C Series**

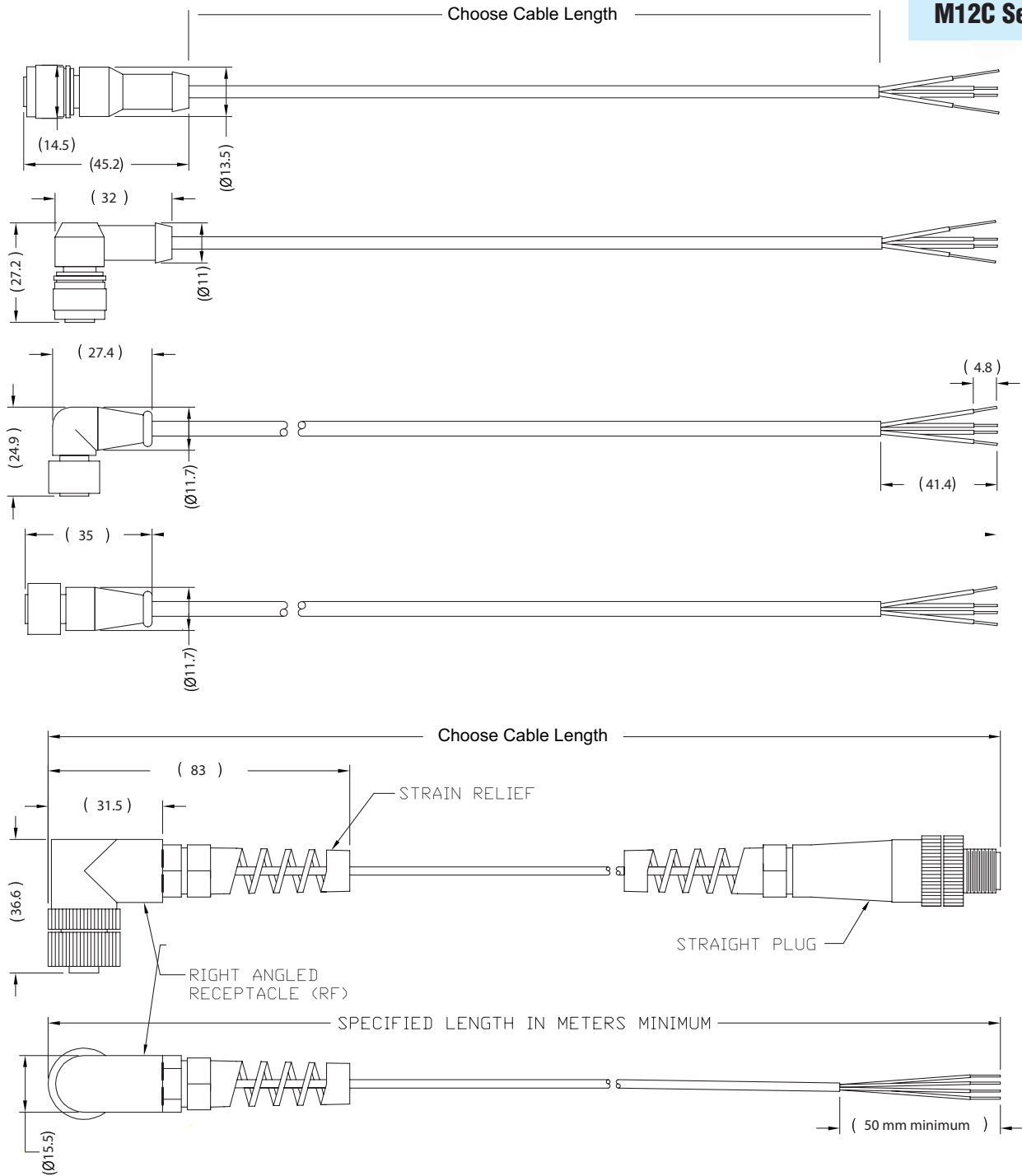

**All measurements in mm**

These extension cables can be used for connecting sensors such as our M12 Style Hygienic Sensors, as well as our PR-21 and PR-22 Industrial RTD Probes. Transmitters or instruments such as Omega's DTG-RTD Digital RTD Thermometer, TX-M12 Transmitter, UWRTD-S-2, UWRTD-2-NEMA Wireless Transmitters or other products which include an M12, 4-pin connector can also use these cables.

- Straight and right angled M12 moulded connector sensor end
- Variety of connection methods to work with your instrumentation
- Available in various lengths

**RTD Pt100 Probes with industrial Head**  
**OMEGA offers a wide range of Pt100 RTD heads**  
**from cast iron to feral iron alloy, also we have**  
**many options available for RTD lengths and threads**

**Miniature Aluminium Protection Head**

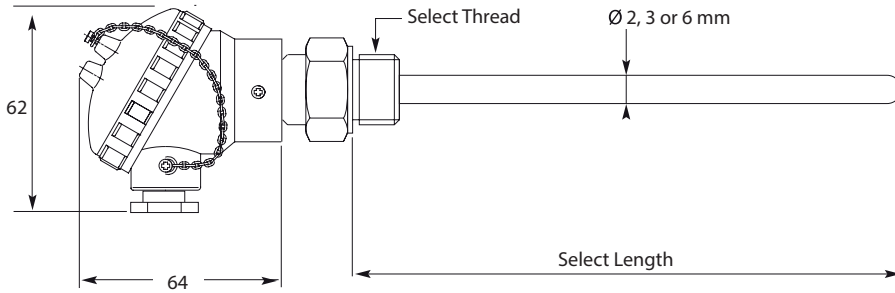

All measurements in mm



**PR-14A**

**Sub-Miniature Aluminium Protection Head**

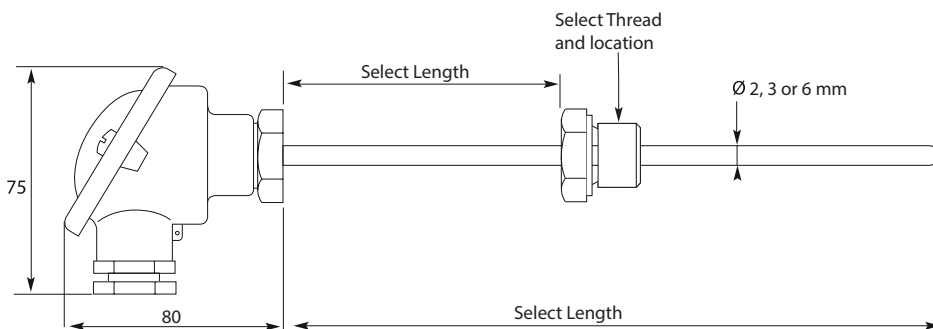

All measurements in mm



**PR-19A Series**

**Aluminium Hinged Top Connection Head**

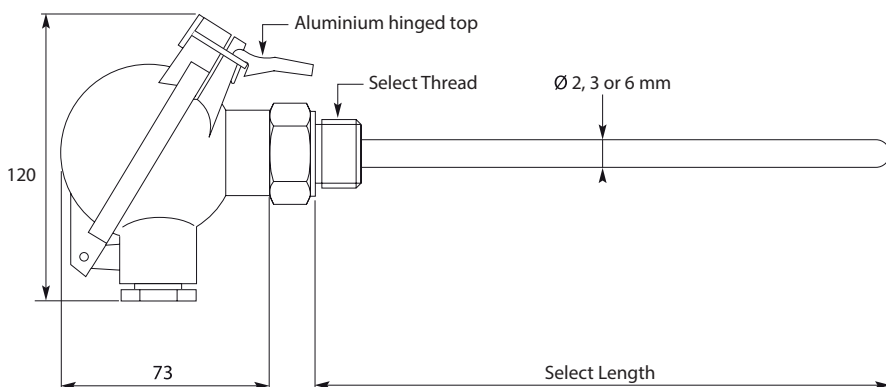

All measurements in mm



**PR-18A Series**



**Cast Iron Connection Head**

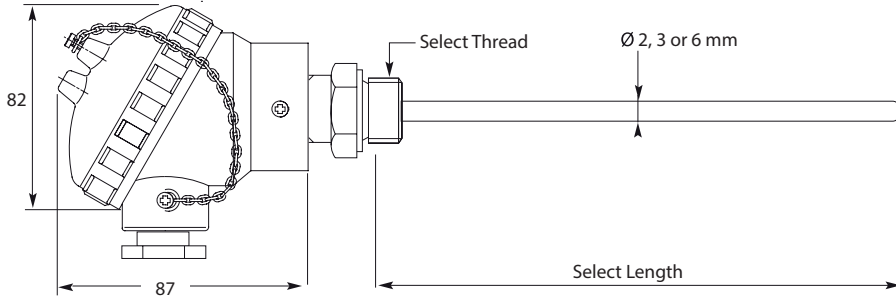

All measurements in mm



**PR12A Cast Iron Head**

**Hygienic Fitting and Protection Head**

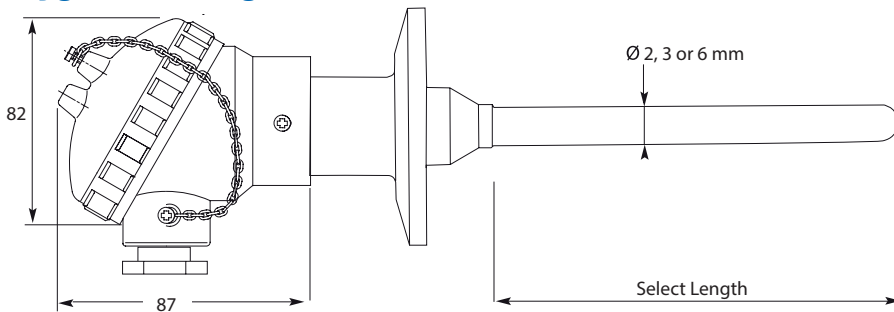

All measurements in mm



**PRS NB9**

Omega's industrial protection head temperature probes are offered in many different mechanical constructions and have multiple options and fittings, making them suitable for a wide range of applications.

Standard probes have a stainless steel tube sheath, and have an operating range of -30 to +350°C.

Mineral insulated (MI) Sheaths are also available and have an extended temperature range of -200 to +650°C .

The following can be specified at time of order:

- Sensor type
- Fixed, replaceable or mineral insulated
- Accuracy class
- Diameter
- Insertion and lagging lengths
- Process fittings and optional head-mount transmitter

**Pt100 Assemblies with DIN B Head, for Industrial Applications**  
**Wide range of process fittings/threads**

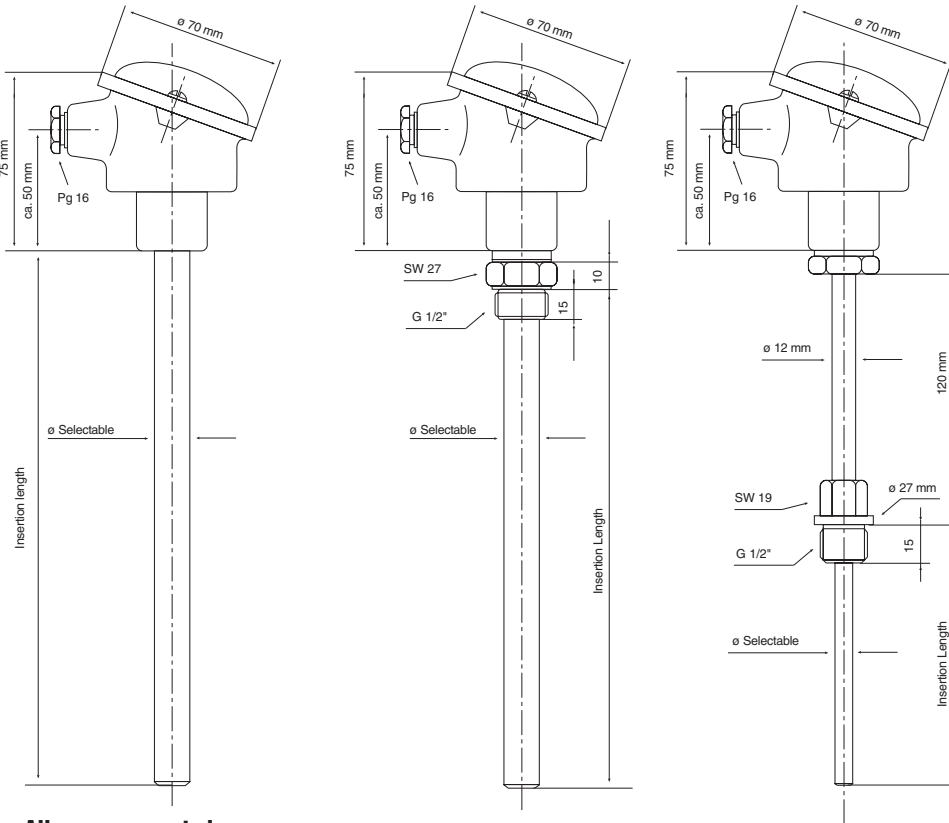

All measurements in mm

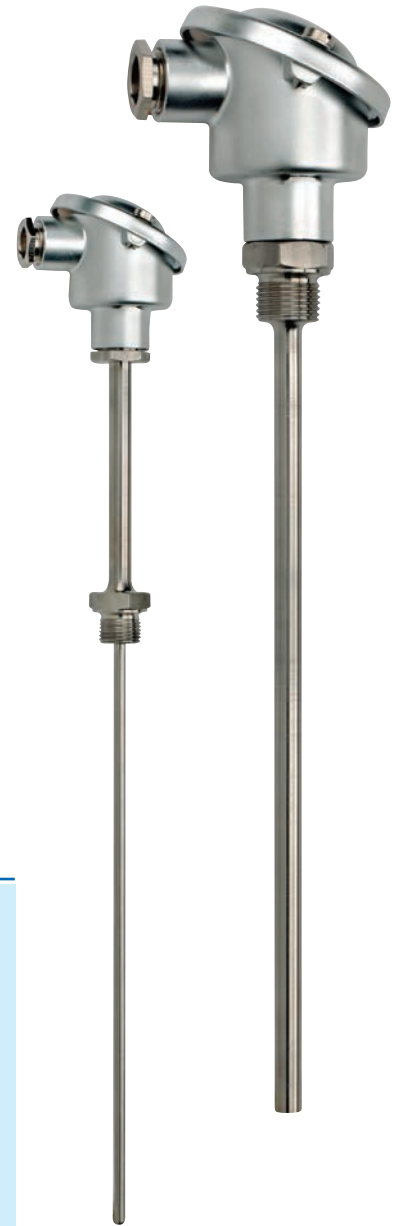

**Mounting Thread Choose from:**

- None
- M18
- G1/2 BSPP
- G1/4 BSPP
- R1/4 BSPP
- R1/2 BSPP
- M18 with lagging ext.
- G1/4 BSPP with lagging ext.
- G1/2 BSPP with lagging ext.

**Sheath Diameter Choose from:**

- 6mm Diameter
- 9mm Diameter
- 11mm Diameter
- 15mm Diameter

**Length Any Length Available:**

Omega's industrial protection head temperature probes are offered in 3 different mechanical constructions and with many options and fittings, making them suitable for a wide range of applications.

The following may be specified at time of order: sensor type, fixed, replaceable or mineral insulated construction, accuracy class, diameter, insertion and lagging lengths, process fittings and optional head-mount transmitter.

- Pt100 in class A, 1/3 DIN & 1/10 DIN available
- Sheath lengths of 20 to 500mm as standard
- Sheath diameters of 6, 9, 11 and 15mm
- Wide range of process fittings/threads

## Terminal Block Pt100 Probe

Terminal block with large knurled-head screws for easy connection of extension wire

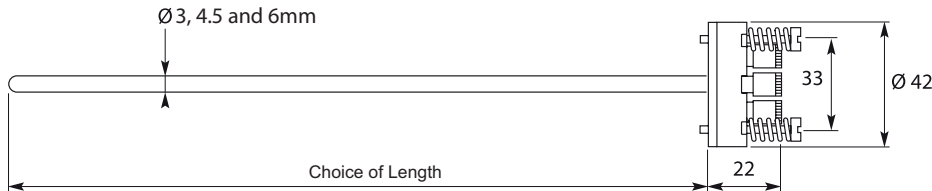
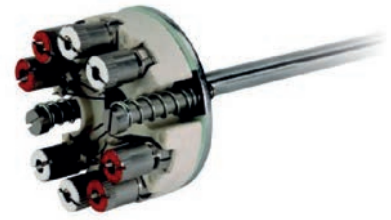

### PR-15A Series

All measurements in mm

The terminal block of the PR-15A is fitted with large knurled-head screw for easy connection of extension cables. Capable of direct immersion up to the block, the PR-15A can easily be mounted into fixtures, pipes and other ducts by using OMEGA compression fittings. Custom diameters, lengths and configurations are available.

- 150, 225, 300, 450 and 600mm sheath lengths standard
- 3, 4.5 and 6mm sheath diameters standard
- Dual element and 4 wire configurations available

## Pipe Plug Pt100 Sensor

Wide range of threads and leads available

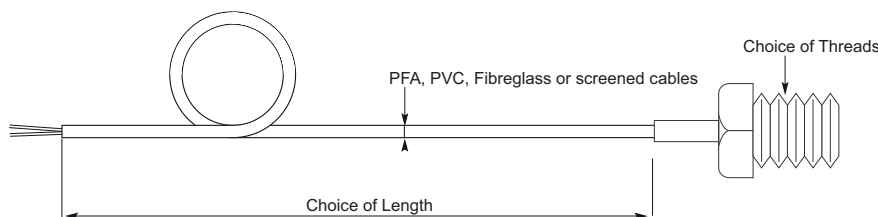
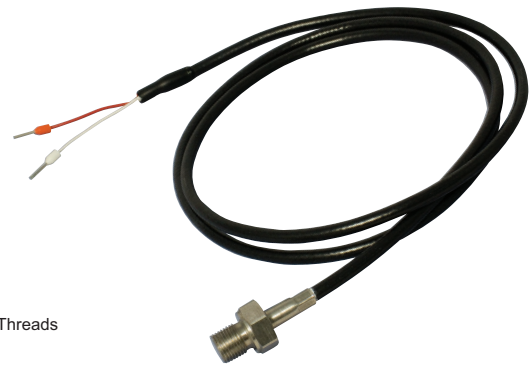

### Pt100-BSP

All measurements in mm

Omega's pipe-plug probes provide reliable service in environments with high vibration and shock. Designed specifically for pipe fitting, they are also used in many other applications, such as sump temperature monitoring.

- Work in vibration environments
- PFA, PVC, Fibreglass and screened cables
- Pt500 and Pt1000 available on request

**Rugged, Weatherproof, Temperature Sensor  
EWSE designed for outdoor and harsh indoor use**

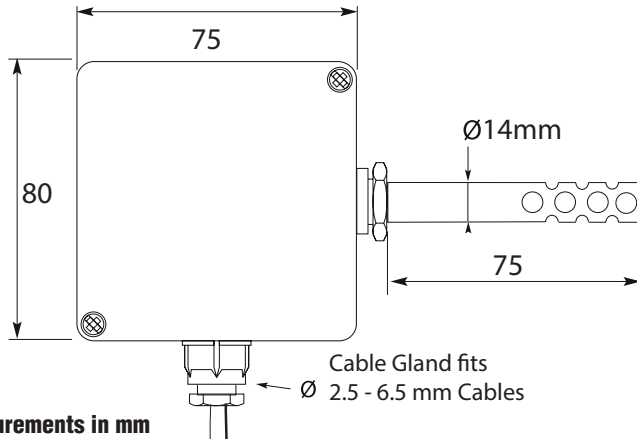

**EWSE Series**

All measurements in mm

Omega's air temperature sensors offer the perfect solution for temperature monitoring outdoors or in demanding environments. A rugged 6 mm diameter sheathed RTD probe is housed in the centre of a 14 mm outer protection tube which is drilled to improve airflow around the sensor. A 4-terminal connector block or 4-20mA transmitter are housed in a tough aluminium alloy enclosure rated to IP65.

- Operating Temperature Range: -50 to 100°C
- Optional built-in 4-20 mA transmitter
- Supplied with IP68 cable gland for electrical connection

**Magnet Mount RTD Pt100 Sensors  
Measure surface temperature of ferrous materials**

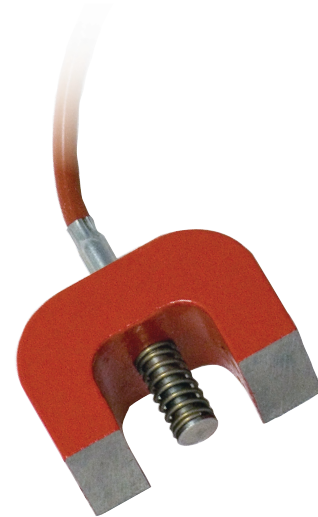
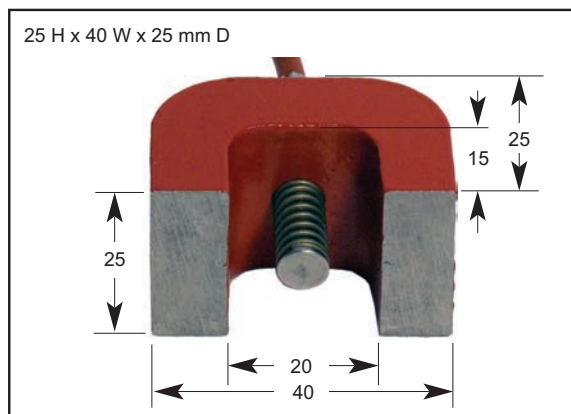

**PRMAG Series**

All measurements in mm

Omega's magnetic-mount RTD surface temperature sensors are available with Pt100, Pt1000 and Pt500 elements. Four wire configuration is standard and a wide range of lead wire insulations and terminations are available. Maximum temperature for the magnet is 300°C

- Measure surface temperature of ferrous materials
- Spring-mounted probe
- 4-wire construction standard

## RTD Temperature Sensor with M4 Threaded Housing Stud mounting Pt100 sensor



Perfect for tight spaces where temperature control is needed

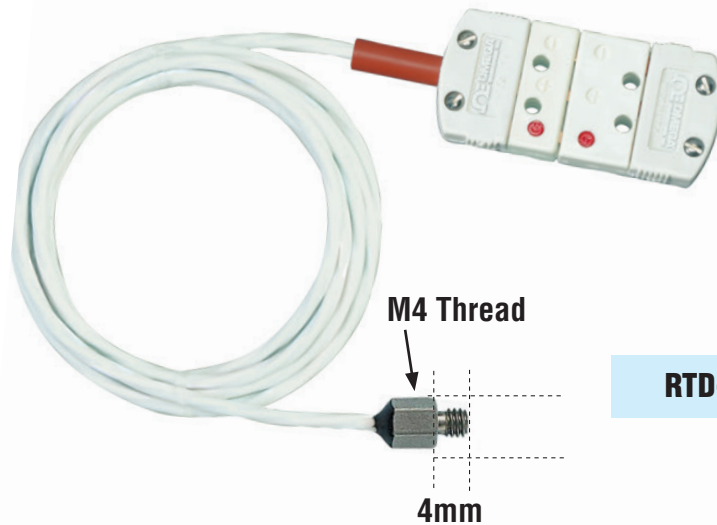

**RTD-850-B**

### Typical Applications

*Environmental and Performance Testing*

*Climate Control/HVAC*

*Power Supplies, Electronic Racks, and Enclosures*

*Temperature Monitoring of Processes, Equipment, and Structures*

### Temperature Range:

*-200 to 750°C  
(model dependent)*

### Other Styles in the PR-800 Series Available

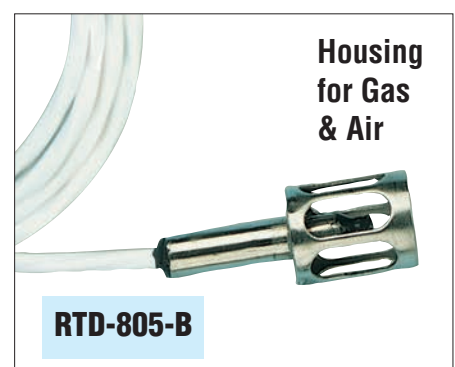
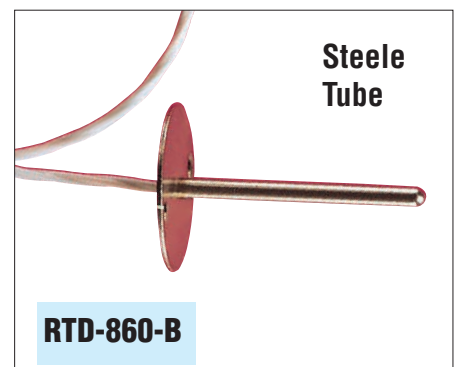
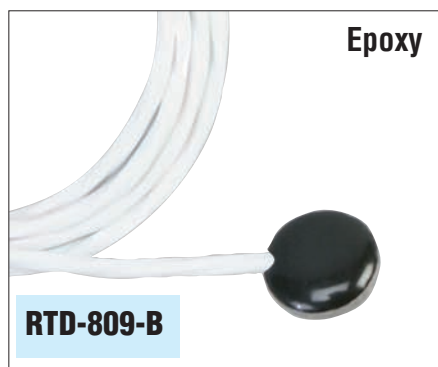

All measurements in mm

The RTD-850M Pt100 sensor is designed for installation in M4 threaded holes or in thin panels or PCB's using a backing nut. Its small size allows for installation in tight spaces such as electronic equipment, power supplies, equipment racks, motors, automated equipment, and many other places.

- Stud mounting Pt100 sensor can be installed in small places. All that is needed is an M4 threaded hole 5mm deep.
- Sensor contains a high-accuracy, 100 Ohm, Class A DIN platinum element, 3-Wire configuration with 1 metre of PFA insulated cable and a 3-Pin mini plug and socket.

## RTD Probes with Transitions and Braided Cables

### PR-11 Pt100 probe with pot seal and spring strain relief

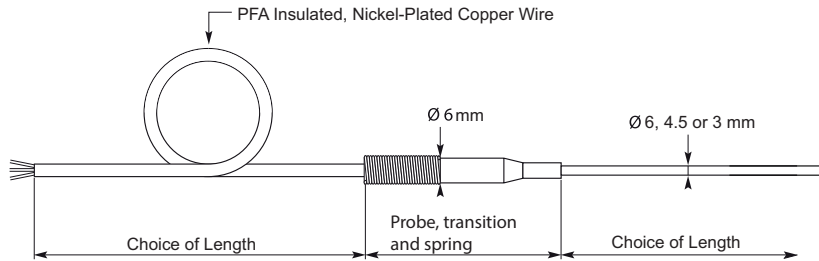

PR-11 Series

All measurements in mm

These durable RTD probes feature a BS EN60751:1996 Class A accuracy Pt100 element with a stainless steel sheath, terminated with a pot seal and spring strain relief with 1 metre of PFA-insulated 7/0.16mm stranded lead wire. The standard probes have a rigid stainless steel tube sheath and have a measurement range of -30 to +250°C.

- Class A accuracy PT100 elements as standard
- Semi-rigid MI sheath construction available as an option
- Many configurations available from stock

## Ultra Precise RTD Sensors

### For industrial, air-stream and laboratory applications

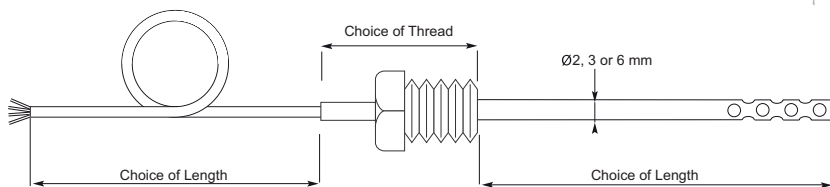

P-ULTRA RTD

All measurements in mm

Omega's temperature probes for industrial and laboratory applications are produced with a wide variety of styles.

They may be specified to your precise requirements by the sensor type in either a closed-end or air-stream style sheath, accuracy, probe length, different threads, wire material in shielded and unshielded versions.

- Available in Two Models:
  - Standard closed end sensor for immersion applications
  - Air/Gas measurement sensors with open ends and vent holes.
- Both models are available as straight sheaths or with the following mounting threads: 1/8, 1/4, 3/8 and 1/2NPT, and 6mm, 8mm and 10mm sizes.

**Low Cost, General Purpose Pt100 Probes**  
**PR-10 with heat-shrink transition from sheath to lead**

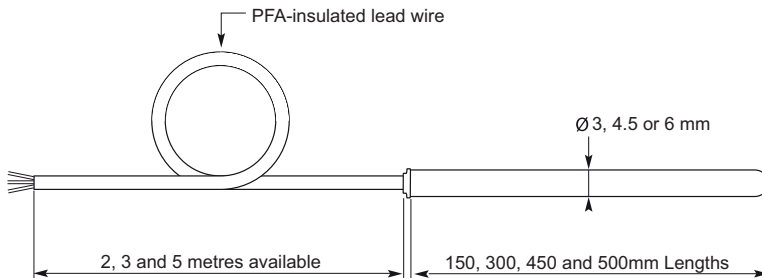
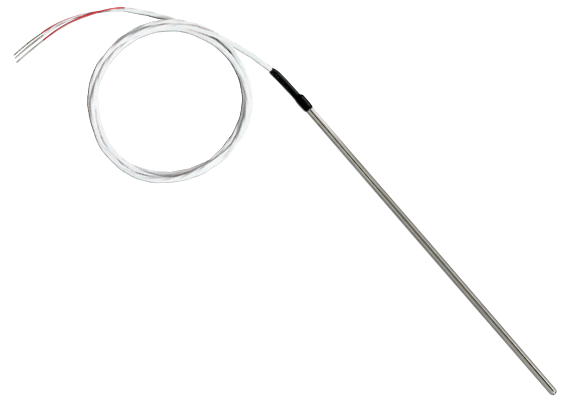

All measurements in mm

**PR-10 Series**

These budget Pt100 probes have excellent accuracy, with a BS EN60751:1996 Class A element fitted inside a rigid stainless steel tube sheath, terminated with heat shrink tubing and 1 metre of PFA-insulated 7/0.16mm stranded lead wire. They are a very low cost option for general purpose use up to 200°C. The basic design also makes for a very compact probe for use where space is limited.

- Measurement range -30 to +200
- Leads terminate with 3 Stripped Wires
- 150, 300, 450 and 500mm Probe lengths standard

**Temperature probe RTD Pt100 with handle**  
**Retractable extension lead wire expands to 1.5m**

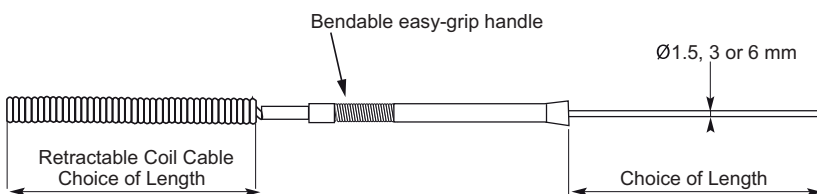

All measurements in mm

**PR-16 Series**

These economical PT100 temperature probes feature BS EN60751:1996 Class A accuracy thin film elements and have an easy grip handle with a coiled cable that expands to 1.5m. The standard probes are made with a rigid stainless steel tube sheath and have a measurement range of -30 to +350°C.

- Rigid stainless steel tube sheath and have a measurement range of -30 to +350°C
- Retractable extension lead wire - expands to 1.5m
- Temperature probe with Class A accuracy Pt100 elements as standard

**Self Adhesive Silicone Patch RTD Surface Sensors**  
**Surface RTD sensor with temperature range from -30 to +150°C**

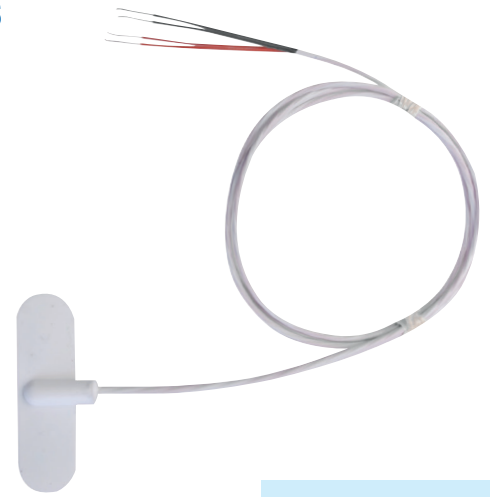
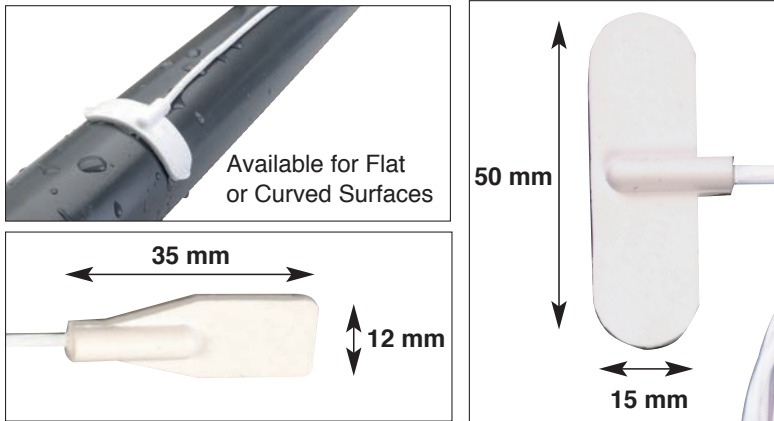

**SA2 Series**

These Platinum Resistance Temperature Sensors (PRT's) are available in 2 different mounting styles for flat or curved surfaces. The integral RTD sensor is bonded onto the inner surface of the self adhesive aluminium foil strip, which is provided for faster response times.

- Surface RTD sensor with temperature range from -30 to +150°C
- Self-adhesive foil backing for easy mounting & fast response
- Available for flat or curved surface

**RTD Surface-Mount RTD**  
**Extra accuracy for critical measurements**

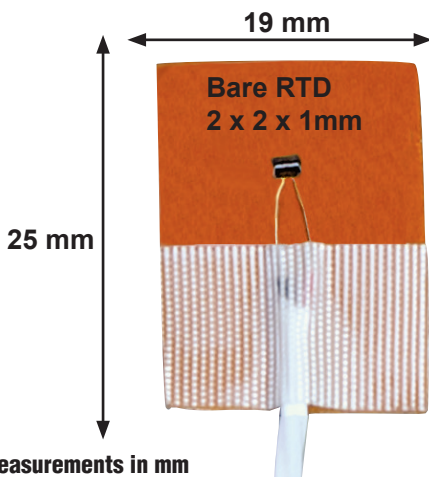

All measurements in mm

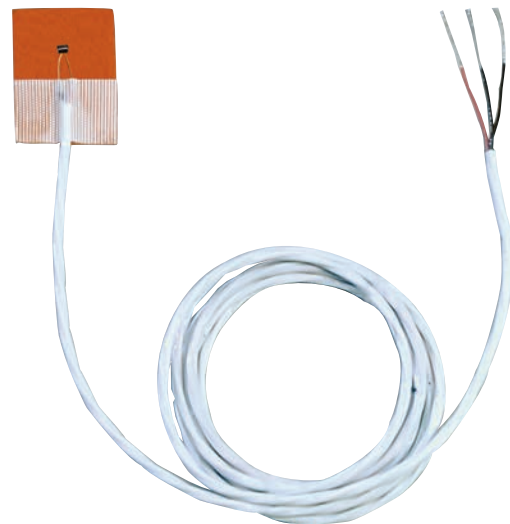

**SA1-RTD Series**

The RTD Pt100 sensor from SA1-RTD series are surface-mount temperature probes perfectly designed to be installed on flat or curved surfaces and provides Class A accuracy for critical temperature monitoring applications. Based on a 2 x 2 x 0.8 mm thin-film platinum Pt100 element and supplied with stripped, 3-wire leads as a standard (connector optional), it can be customised for use in a wide variety of applications.

- Temperature RTD Pt100 sensor  
 100 Ω DIN Class A ( $\pm 0.06 \Omega$  or  $\pm 0.15^\circ\text{C}$  at  $0^\circ\text{C}$ ) Accuracy Standard
- Stocked in 1 m Lengths; Also available in 2 and 3 m and custom length lead wires
- Stainless steel overbraid option to reduce electrical noise and protect lead wire from abrasion



**Thin Film Platinum RTD Elements  
Pt100 and Pt1000 ohm**

These RTD elements are the same thickness as this line—  
0.8 mm.

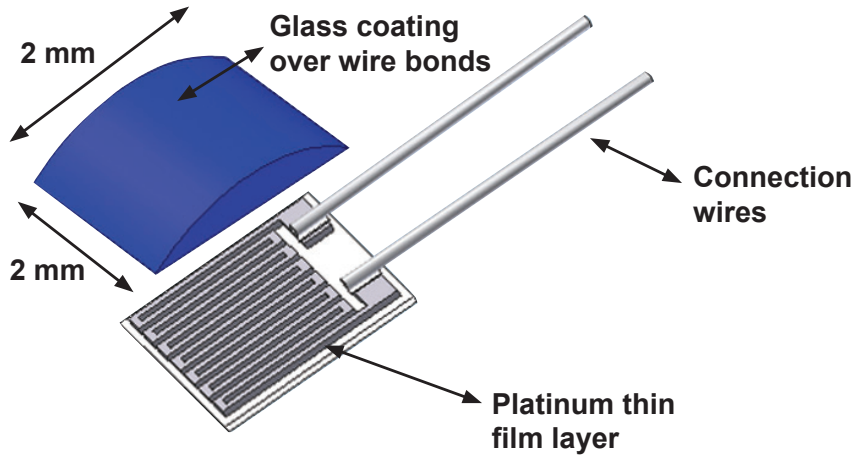

All measurements in mm

**F2020 Series**

OMEGAFILM® platinum RTD elements are manufactured using materials and processes similar to those employed in the manufacture of integrated circuits. This results in a rugged, reliable sensing element that can be produced in a wide range of sizes, resistances, and accuracies to meet even the most demanding of applications.

- Temperature range -50 to +300°C
- Single and dual element configurations
- Response times equivalent or better than wire wound elements

**Hermetically Sealed RTD Sensors  
Ideal in areas of limited space**

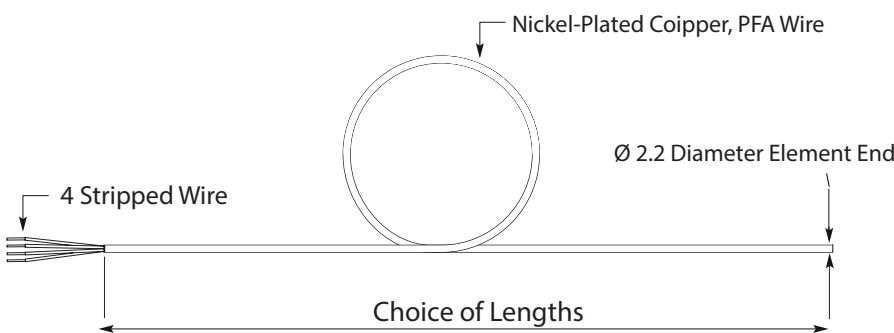

**HSRTD Series**

All measurements in mm

OMEGA's HSRTD style PFA insulated wire probes are hermetically seal-welded at the tip to give a continuous PFA coating along the entire length. Omega's unique manufacturing process produces no increase in diameter or change in shape at the tip, allowing the sensor to be installed into areas of limited space.

- Operating temp. range of -60 to +250°C
- Dielectric strength type tested to 3kV AC RMS
- 4 wire Pt100 Ohm class A elements standard

# RTD Temperature Sensors With Micro-DIN Connectors

## Micro-DIN connectors for fast replacement

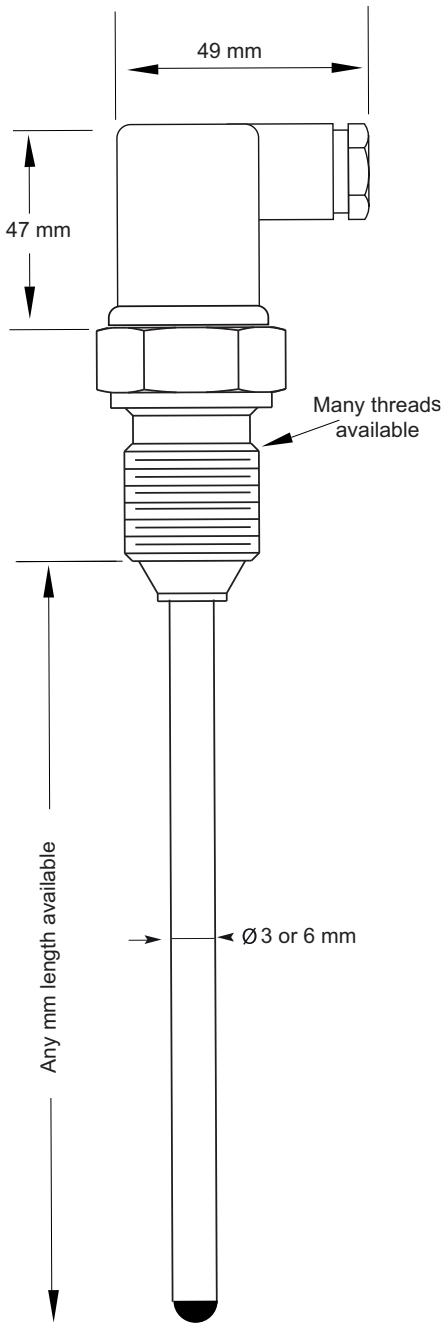

### PR-24 Series

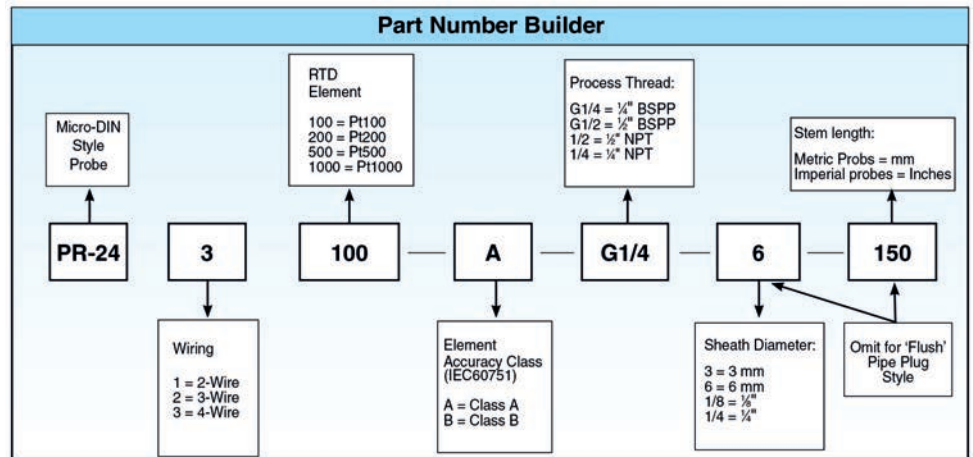

All measurements in mm

Omega's PR-24 Series RTD probes feature industry standard micro-DIN connectors for ease of installation and fast replacement. The IP65 rated connector with an all stainless steel sheath and integral thread construction is ideally suited for use in demanding industrial environments.

- Maximum temperature: 500°C process, 125°C connector
- Minimum temperature: -50°C process, -30°C connector
- Any sheath length available

## RTD Extension Wire

Available with PFA, fiberglass or PVC

This cable is great for manufacturing sensors or for use as extension wire. Available in 2, 3 and 4 wire constructions, two color codes (red/black or red/white), three insulation and jacketing materials (PFA, Fiberglass and PVC) and three conductor sizes (#20 AWG Solid, #24 or #26 AWG Stranded) this cable will work with a wide variety of applications. Standard spool lengths include 25, 50, 100, 200, 500 and 1000 feet.

- #24 or #26 AWG Stranded Nickel Plated Copper Conductors Available in Most Styles
- Red/Black or Red/White Color Codes Available in Most Styles
- Available with Optional Stainless Steel Overbraid
- Cable Available in 25, 50, 100, 200, 500 and 1000 Foot Spools Standard

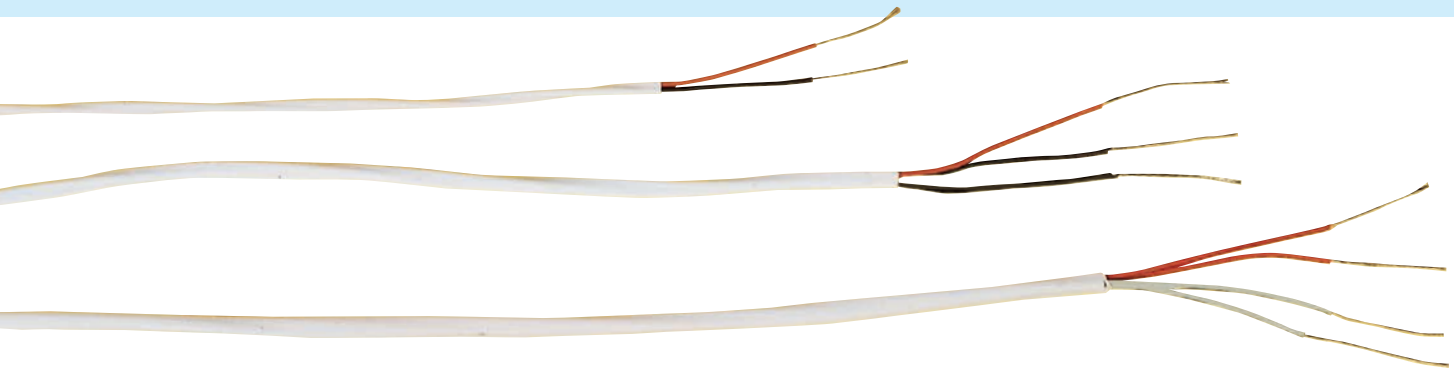

AWG No.	Model Number	No. of Cores	Wire Dia.	Conductor Material	Conductor	Overall	Braid	°C	°F	Nominal Size: mm	Wt. kg/300 m	Colour Code	Outer Jacket Colour
<b>Glass Insulation</b>													
24	EXGG-2CUI-26S	2	7/0.16	NPC			None	482	900	2.1 Ø	2.2	1 Red 1 White	White
24	EXGG-3CUI-26S	3	7/0.16	NPC	Glass braid	Glass braid	None	482	900	2.2 Ø	3.2	2 Red 1 White	White
24	EXGG-4CUI-26S	4	7/0.16	NPC			None	482	900	2.4 Ø	4.2	2 Red 2 White	White
<b>Glass with Outer Braid Insulation</b>													
24	EXGG-2CUI-26S-SB	2	7/0.16	NPC	Glass braid	Glass braid	SST	482	900	2.8 Ø	5.2	1 Red 1 White	SST braid
24	EXGG-3CUI-26S-SB	3	7/0.16	NPC			SST	482	900	2.9 Ø	6.2	2 Red 1 White	SST braid
24	EXGG-4CUI-26S-SB	4	7/0.16	NPC			SST	482	900	3.1 Ø	7.2	2 Red 2 White	SST braid
<b>Neoflon PFA Insulation</b>													
24	EXTT-2CUI-26S	2	7/0.16	NPC	PFA	PFA	None	260	500	2.1 Ø	2.2	1 Red 1 White	White
24	EXTT-3CUI-26S	3	7/0.16	NPC			None	260	500	2.2 Ø	4.2	2 Red 1 White	White
24	EXTT-4CUI-26S	4	7/0.16	NPC			None	260	500	2.4 Ø	5.2	2 Red 2 White	White
<b>PFA with Screen Insulation</b>													
24	EXTT-2CUI-26S-SB	2	7/0.16	NPC	PFA	PFA	SST	260	500	2.8 Ø	5.2	1 Red 1 White	SST braid
24	EXTT-3CUI-26S-SB	3	7/0.16	NPC			SST	260	500	2.9 Ø	7.2	2 Red 1 White	SST braid
24	EXTT-4CUI-26S-SB	4	7/0.16	NPC			SST	260	500	3.1 Ø	8.2	2 Red 2 White	SST braid
<b>Polyvinyl (PVC) Insulation</b>													
24	EXPP-2CUI-24S	2	7/0.2	NPC	Polyvinyl	Polyvinyl	None	105	221	2.1 x 3.4	5	1 Red 1 White	White
24	EXPP-3CUI-24S	3	7/0.2	NPC			None	105	221	4.22 Ø	6	2 Red 1 White	White
24	EXPP-4CUI-24S	4	7/0.2	NPC			None	105	221	4.3 Ø	7	2 Red 2 White	White
<b>Polyvinyl (PVC) with Screen Insulation</b>													
24	EXPP-2CUI-24S-TCB-P	2	7/0.2	NPC	Polyvinyl	Polyvinyl	Tinned copper	105	221	2.8 x 4.0	8	2 Red 2 White	White
24	EXPP-3CUI-24S-TCB-P	3	7/0.2	NPC			Tinned copper	105	221	4.9 Ø	9	2 Red 2 White	White
24	EXPP-4CUI-24S-TCB-P	4	7/0.2	NPC			Tinned copper	105	221	5.0 Ø	10	2 Red 2 White	White

Maximum temperature is for wire or insulation, whichever is lower. Weight of reel and wire rounded to the next highest kilogram; does not include packing material. Conductors can be welded (spliced) within reel.

Ordering Example: EXTT-3CUI-26S-300M, 300 m of 7/0.16 mm diameter conductors, Neoflon insulated, 3 core, Call our sales team, 0800 488 488, for pricing.

# RTD/Pt100 Selection Guide

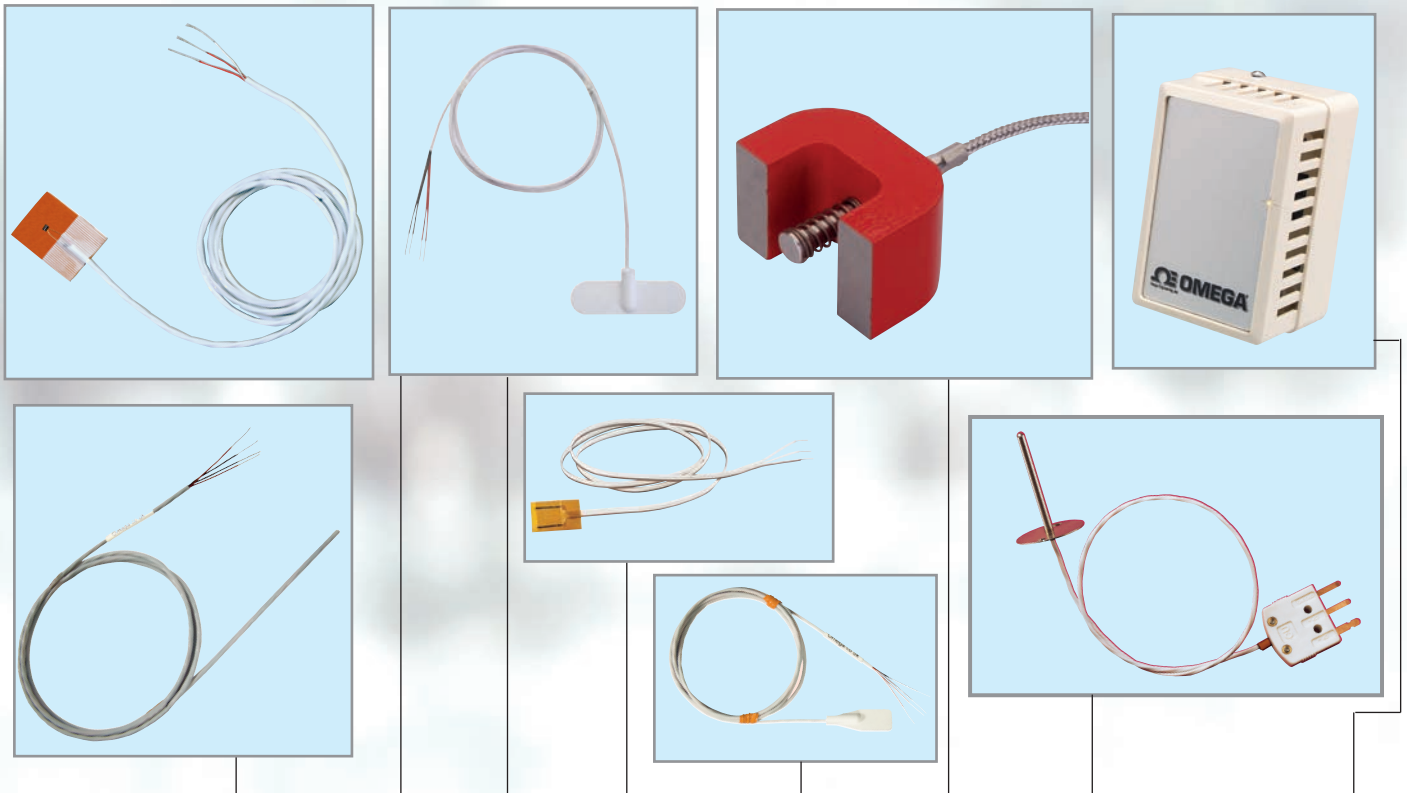

Series No	HSRTD	SA1-RTD	RTD-2	SRTD	SA2C	PRMAG	RTD-800	EWS
Probe Type	Hermetically Sealed	Self Adhesive Surface Sensor	Element with Leads	Cement-On Surface RTD	Self Adhesive Surface Sensor	Magnetic Mount	Immersion, Air and Surface	Wall Mount
Termination Style	Stripped Leads Standard	Stripped Leads Standard	Stripped Leads Standard	Stripped Leads Standard	Stripped Leads Standard	4-Wire Cable, PFA, PVC or Glass Fibre	Miniature Connectors	Stripped Leads Standard
Features	Resistant to Acids	Standard or High Accuracy Tolerances	Small Diameter Extremely Flexible	Standard or High Accuracy Tolerances	Flexible Patch	6kg Pull Magnet	Numerous Configurations	Wall Mount Housing
Typical Applications	Liquids	Surface	General Purpose	Surface Measurement	Flat or Curved Surface	Surface Measurement	General Purpose	Ambient Temperature
Options Available	1000 Ω Elements, Long Length	1000 Ω Elements, Long Length	Factory Calibration, Connector Options	Factory Calibration, Transmitters, Handheld Meters	1000 Ω Elements, Long Length	Long Length and Insulation Type	Class A or Class B Accuracies	Factory Calibration

# RTD/Pt100 Selection Guide

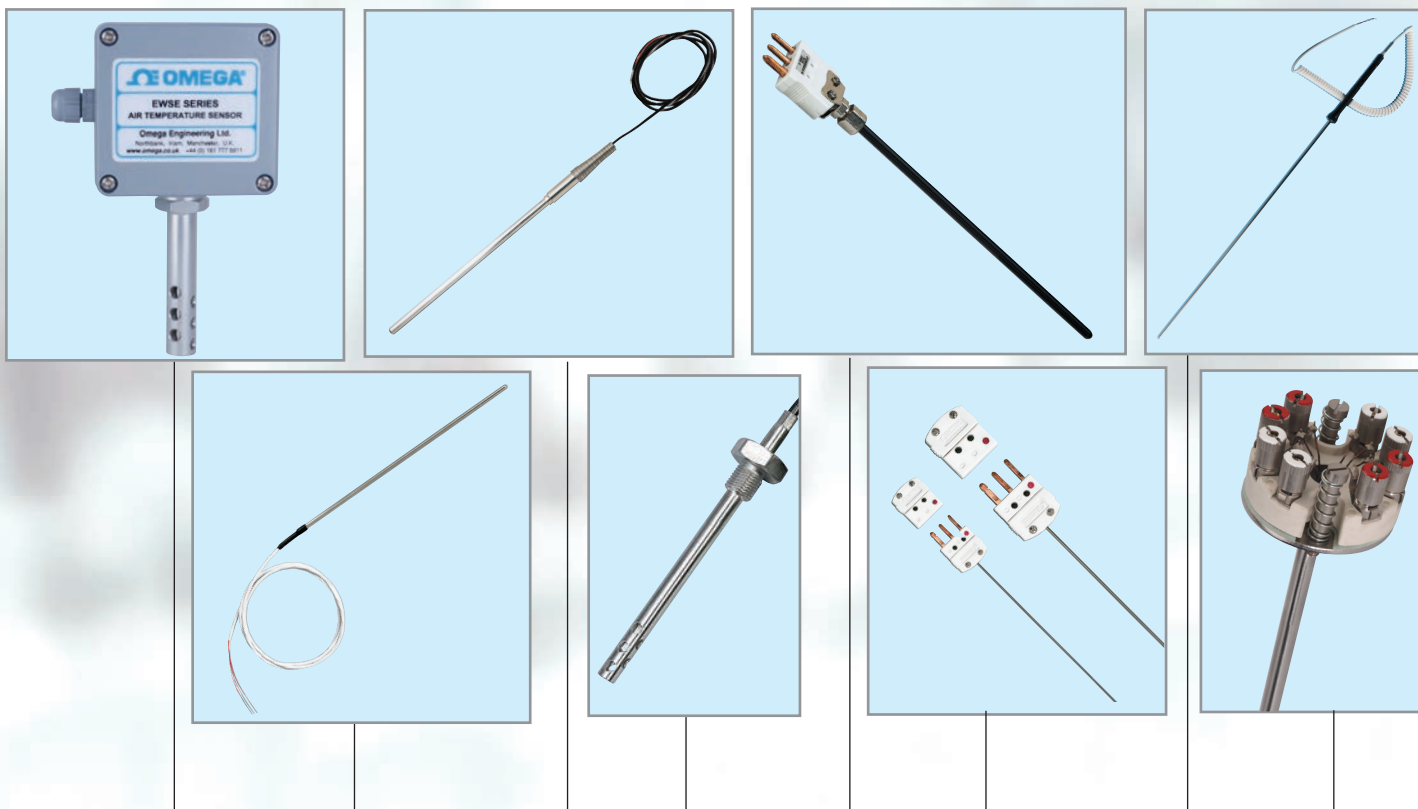

Series No	EWSE-Pt100	PR-10	PR-11	P-ULTRA RTD	PR-13	PR-17	PR-16	PR-15A
Probe Type	Rugged, Weatherproof Wall Mount	Straight	Tension Fitting	Immersion with Fitting Option	Quick Disconnect	Quick Disconnect	Utility Handle	Wafer Type Epoxy
Termination Style	Screw Terminals Through IP68 Cable Gland	Stripped Leads Standard	Stripped Leads Standard	Stripped Leads Standard	OTP Heavy Duty 3-Prong Connector	MTP Miniature 3-Prong Connector	Stripped Leads Standard	Screw Terminal
Features	Wall Mount	Low Cost Simple Design	Cable Strain Relief Spring, Rugged	Ultra Precise Accuracy Liquid & Air	Heavy Duty Quick Disconnect	Miniature Quick Disconnect	Retractable Cable, Moulded Handle	Exposed Connections
Typical Applications	Outdoor Ambient Temperature Sensing	Light Duty General Purpose	Heavy Duty General Purpose	Laboratory Use, Air Temp Measurement	Industrial Applications	Industrial Heavy Duty	Handheld Meters	Air & Liquid
Options Available	Built-in Transmitter	PFA Coating, Custom Bending, Factory Calibration, Transmitters	PFA Coating, Custom Bending, Factory Calibration, Transmitters	Class A, 1/3 & 1/10 DIN Accuracies, Various Mounting Threads	Imperial & Metric Sizes, Optional Handles	Imperial & Metric Sizes, Optional Handles	Factory Calibration, Handheld Meters	PFA Coating, Factory Calibration

# RTD/Pt100 Selection Guide

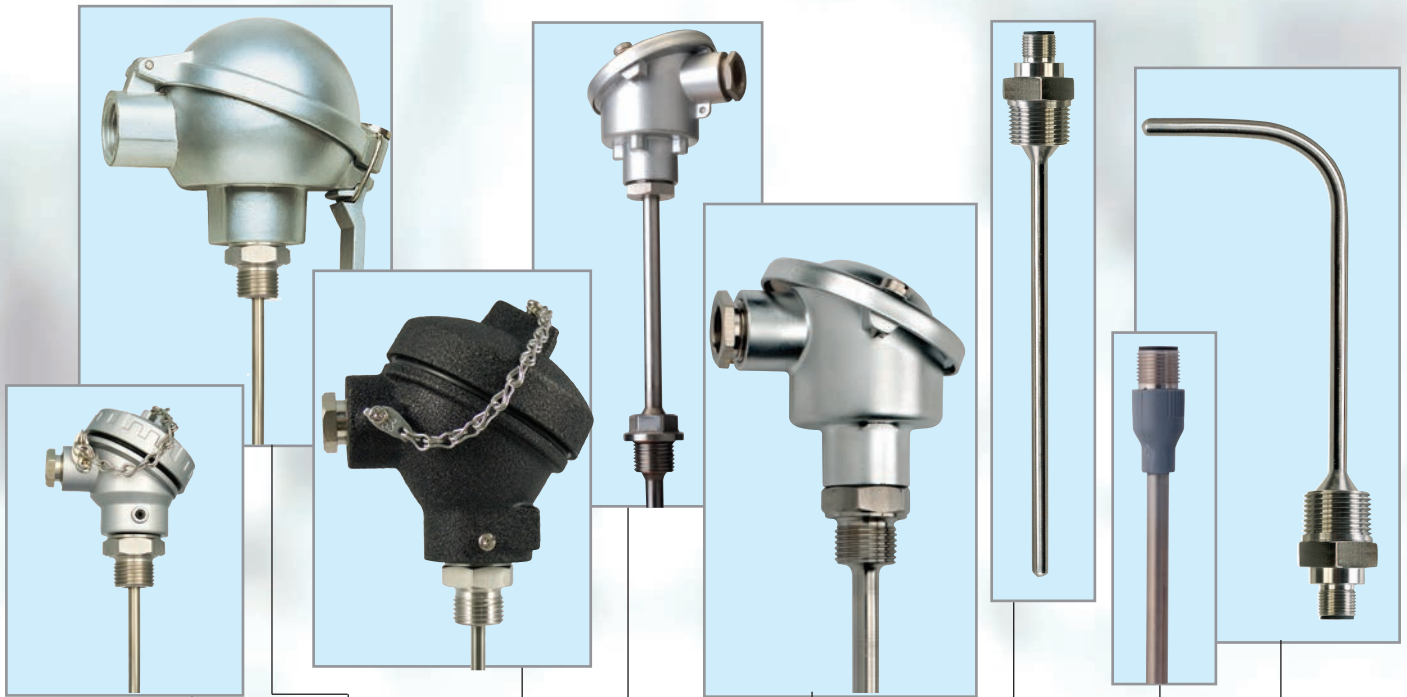

Series No	PR-14A	PR-18A	PR-12A	PR-19A	T3 Head Probes	PR-21	PR-22	PR-26
Probe Type	Miniature Aluminium Screw Top Protection Head	Aluminium Flip Top Protection Head	Cast Iron Screw Top Protection Head	Miniature Aluminium Flip Top Protection Head	DIN B Protection Head Standard	316LSS Sheath and Connector Housing	316LSS Sheath with Moulded Connector	316LSS Sheath & Housing
Termination Style	Screw Terminals	Screw Terminals	Screw Terminals	Screw Terminals	Wide Range of Process Fittings/Threads	M12 Connector	M12 Connector	M12 Connector
Features	Pt100 or 1000 Elements. Class A, 1/3 DIN, 1/10 DIN Accuracy Options	Class A Accuracy PT100 Elements Used as Standard	Class A Accuracy PT100 Elements Used as Standard	Standard 3-Wire, 2 and 4-Wire Also Available	Probes Individually Pressure and Insulation Tested	Pt100 or Pt1000 Class A, 4-Wire Platinum RTD Elements per IEC60751 Standard	Standard Sheath Lengths of 100, 150, 250, 350, 500, 750 and 1000 mm	Class A, Pt100 or Pt1000 4-Wire Platinum RTD Elements per IEC60751 Standard
Typical Applications	Industrial Heavy Duty	Industrial Heavy Duty	Industrial Heavy Duty	Industrial Heavy Duty	Industrial Heavy Duty	Industrial Applications	Industrial Applications, Laboratory	Automation, Packaging, Food and Beverage.
Options Available	PFA Coating, Custom Bending	PFA Coating, Custom Bending	PFA Coating, Custom Bending	PFA Coating, Custom Bending	Optional Head Mount Transmitters	Available With a G 1/4, G 1/2, M10x1, or No Mounting Thread	In-Line, Remote and Wireless Transmitters Available	Any Lengths Available

# RTD/Pt100 Selection Guide

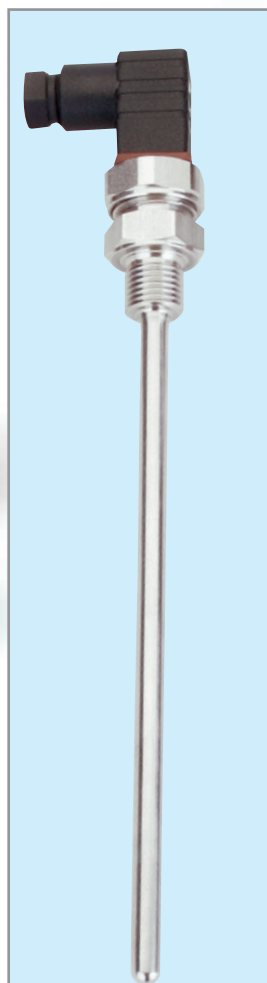
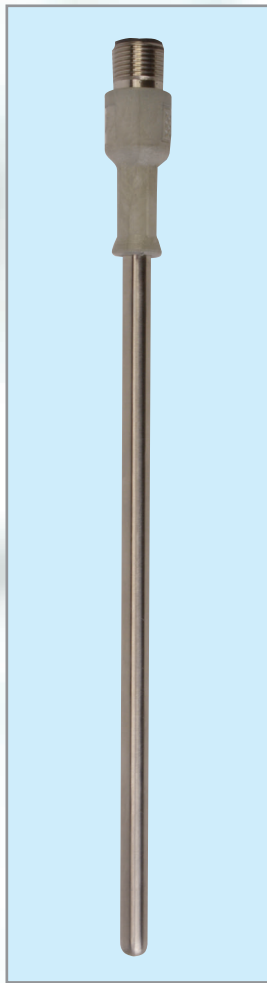

Series No	PR-31	PR-24	Pt100-BSP
Probe Type	316LSS Sheath with Moulded Connector	Rugged Mineral Insulated Construction	Pipe Plug Sensor
Termination Style	M12 Connector	Micro-DIN Connector	PFA, PVC, Fibreglass and Screened Cables
Features	Available in 100 and 1000Ω Values	High Accuracy, with Pt100 Class A, 4-Wire Construction as Standard	G 1/8, G 1/4, G 1/2, M8 and M10 Thread Sizes
Typical Applications	High Vibration, High Temperature Environments	Demanding Industrial Environments	Pipe or Tank Installation
Options Available	Bendable Probe Options Available	Any Sheath Length Available	Pt500 and Pt1000 Available on Request.

# European Sales & Service



**We have multilingual sales staff well-versed in worldwide trade. International payment conveniences such as credit cards, bank transfers, and acceptance of local currencies make it easy for customers around Europe to work with OMEGA.**



**Watch our manufacturing & capability video.**



**Benelux**  
 Tel: (+31) 070 770 3815  
 Fax: (+31) 070 770 3816  
 Free Phone: 0800 099 3344  
[esales@omega.nl](mailto:esales@omega.nl)  
[es.omega.com](http://es.omega.com)



**Italy**  
 Tel: (+39) 022 333 1521  
 Fax: (+39) 022 333 1522  
 Free Phone: 800 906 907  
[commerciale@it.omega.com](mailto:commerciale@it.omega.com)  
[it.omega.com](http://it.omega.com)



**Denmark**  
 Tel: (+45) 43 31 48 42  
 Fax: (+45) 43 31 48 43  
 Free Phone: 80 25 14 43  
[salg@dk.omega.com](mailto:salg@dk.omega.com)  
[dk.omega.com](http://dk.omega.com)



**Spain**  
 Tel: (+34) 911 776 121  
 Fax: (+34) 911 776 122  
 Free Phone: 800 900 532  
[ventas@es.omega.com](mailto:ventas@es.omega.com)  
[es.omega.com](http://es.omega.com)



**France**  
 Tel: (+33) 01 57 32 48 17  
 Fax: (+33) 01 57 32 48 18  
 Free Phone: 0805 541 038  
[commercial@omega.fr](mailto:commercial@omega.fr)  
[omega.fr](http://omega.fr)



**United Kingdom**  
 One Omega Drive,  
 River Bend Technology Centre  
 Northbank, Irlam, Manchester  
 M44 5BD United Kingdom  
 Tel: +44 (0) 161 777 6611  
 Fax: +44 (0) 161 777 6622  
 Free Phone: 0800 488 488  
[sales@omega.co.uk](mailto:sales@omega.co.uk)  
[omega.co.uk](http://omega.co.uk)



**Germany**  
 Daimlerstrasse 26,  
 D-75392 Deckenfronn  
 Germany  
 Tel: 07056-9398-0  
 Fax: 07056-9398-29  
 Free Phone: 0800-8266342  
[info@omega.de](mailto:info@omega.de)  
[omega.de](http://omega.de)