

CAP-XX

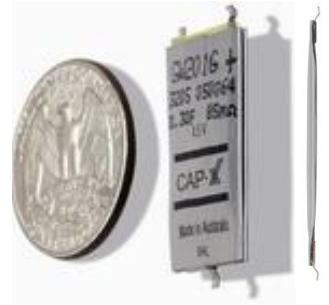

Supercapacitors

Product Guide

Only applies to
GA, GZ, GS, GW, HA, HZ, HS & HW series

Oct 2023

Version: 6.6





Contents & Revision History

Contents

| | |
|--|----|
| 1. Key Features of CAP-XX Supercapacitors..... | 3 |
| 2. Typical Applications | 3 |
| 3. Product Range..... | 3 |
| 4. G Series Product Specifications..... | 4 |
| 5. H Series Product Specifications..... | 5 |
| 6. Storage & Operation Metrics..... | 6 |
| 7. Energy & Power Density | 7 |
| 8. Product Names..... | 7 |
| 9. Product Markings..... | 8 |
| “S” & “W” Dual Cells (Note: previous C & ESR specification shown on picture)..... | 8 |
| “S” & “W” Single Cells (Note: previous C & ESR specification shown on picture) | 8 |
| “A” Dual Cells (Note: previous C & ESR specification shown on picture)..... | 8 |
| “A” Single Cells (Note: previous C & ESR specification shown on picture) | 8 |
| 10. Batch Codes | 9 |
| “S”, “W” & “A” series devices | 9 |
| 11. Transportation & Storage..... | 9 |
| IATA Dangerous Goods Regulations..... | 9 |
| Storage Conditions | 9 |
| 12. Packaging & Package Quantities..... | 10 |
| Packaging for Shipment..... | 10 |
| Packing Tray for “S” series devices | 10 |
| Packing Tray for “W” series devices | 11 |
| Packing Tray for “A” series devices | 11 |
| 13. Cautions Before Use..... | 12 |
| 14. Soldering & Assembly..... | 12 |
| Placement..... | 12 |
| Soldering..... | 12 |
| Washing..... | 13 |
| Drying..... | 13 |
| Conformal Coatings & Potting..... | 13 |
| 15. Safety | 14 |
| Failure modes | 14 |
| Resistance to Shock | 14 |
| Resistance to Vibration | 14 |
| Drop-Test | 14 |
| Exposure to an Open Flame | 15 |
| Exposure to Heat | 15 |
| Pressure..... | 15 |
| Puncture..... | 15 |
| 16. Dimensional Stability & Low Pressure Environments | 16 |
| 17. Response to Over-Temperature Events..... | 16 |
| 18. Certifications & Compliances | 16 |
| ISO 9001-2008..... | 16 |
| Underwriter’s Laboratory (UL 810A) | 16 |
| RoHS | 16 |
| REACH | 17 |
| Rare Earth Metals & Conflict Metals | 17 |
| Halogens..... | 17 |
| 19. Notes & Disclaimers | 17 |



Contents & Revision History

| | |
|---|----|
| 20. Product Drawings: Mechanical & Electrical | 18 |
| “S” Package Dual Cell Devices | 18 |
| “W” Package Dual Cell Devices | 19 |
| “A” Package Dual Cell Devices | 20 |
| “Z” Package Dual Cell Devices | 21 |
| “S” Package Single Cell Supercapacitors | 22 |
| “W” Package Single Cell Supercapacitors | 23 |
| “A” Package Single Cell Supercapacitors | 24 |
| “Z” Package Single Cell Supercapacitors | 25 |
| 21. Contact Information | 26 |
| Principal Office | 26 |
| Sales & Product Enquiries | 26 |
| Distributors | 26 |

Revision History

| Release | Release Date | Author |
|---------|-------------------|--------------------|
| v1.0 | February 18, 2013 | Peter Buckle |
| v1.1 | April 3, 2013 | Peter Buckle |
| v2.0 | July 1, 2014 | Peter Buckle |
| v2.1 | July 14, 2015 | Bernd Failenschmid |
| v2.2 | August 24, 2015 | Bernd Failenschmid |
| V3.0 | October 12, 2015 | Pierre Mars |
| V4.0 | June 22, 2016 | Pierre Mars |
| V5.0 | February 15, 2017 | Song Lau |
| V6.0 | January 29, 2018 | Song Lau |
| V6.1 | July 24, 2018 | Pierre Mars |
| V6.2 | Jan 31, 2019 | Pierre Mars |
| V6.3 | April 17, 2020 | Julia Leem |
| V6.4 | November 16, 2022 | Henry Huang |
| V6.5 | December 13, 2022 | Henry Huang |
| V6.6 | October 26, 2023 | Henry Huang |

1. Key Features of CAP-XX Supercapacitors

- **Ultra-thin** prismatic cells and modules: Ideal for use in space-constrained devices
- Exceptional **power density** (up to **128 kW/litre**), with best-in-class **ESR (from 15 mΩ)**
- High **energy density** (up to **1.9 Wh/litre**), offering high **Capacitance** in small cells
- True, **continuous operating voltage** of up to **2.75V/cell** (H series; 2.9V peak)
- **High temperature rating** (H series; **85°C maximum**)
- Excellent **low temperature performance** (G series; ~2x nominal ESR at -30°C)
- Very **low leakage current (<1 μA)** and **ultra-low minimum charge current (<20 μA)**
- Virtually **unlimited charge-discharge cycle life**
- Excellent **frequency response** ($C_{EFFECTIVE}$)
- **RoHS** and **REACH** compliant, Lead-free, Halogen-free and Conflict metal-free
- **UL-810** and **ISO 9001:2015** certified

2. Typical Applications

- **Peak power for pulsed loads**
 - ✓ Isolate the source from fluctuations in the load (input smoothing).
 - ✓ Extend battery life and run-time, especially when “old or cold”.
 - ✓ Enable the use of cheaper, smaller, lower power batteries.
- **Ride-through power for mission-critical applications**
 - ✓ Isolate the load from fluctuations in the source (output smoothing).
 - ✓ Remove the need for back-up batteries and impact-resistant connectors.
 - ✓ Provide a low maintenance, uninterruptable on-board power supply.
- **Energy storage for energy harvesters and quick charge power supplies**
 - ✓ Environmentally friendly, low maintenance alternative to rechargeable batteries.
 - ✓ Efficient charging, with minimal losses, from variable / low power sources.
 - ✓ Ultra-quick charging via cable, cradle or induction to maximize operating time.

3. Product Range

Cells or Modules:

Choose from:

- Single cells, for ultra-thin designs & primary batteries/harvesters; or
- Dual cell modules, for rechargeable batteries & USB power supplies.

Series:

G series devices operate at 2.5V/cell (2.75V peak) and have an operating temperature range of -40°C to +70°C.

H series devices operate at 2.75V/cell (2.9V peak) and can tolerate excursions to +85°C.

Packages:

- “S” = 39.0mm x 17.0mm
- “W” = 28.5mm x 17.0mm
- “A” = 20.0mm x 18.0mm





Product Specifications

4. G Series Product Specifications

| Dual cell modules (2 cells connected in series) | | | | | | |
|--|---------------------------|--|---|-------------------|---------------------------------|------------------------|
| Voltage & Temperature | Product Name ¹ | CAP ² (± 20%) ³ | ESR ² (max = Nom +20%) ³ | Body Size (mm) | Thickness ⁴ (max) | Minimum Order Quantity |
| 5.0V _{nominal} 5.5V _{peak} -40°C to +70°C T _{max} = 70°C | GZ215F | 90 mF | 110 mΩ | 20.0 x 15.0 | 2.5 mm | TBA |
| | GA209F | 90 mF | 95 mΩ | 20.0 x 18.0 | 2.1 mm | 2,000 |
| | GA230F | 400 mF | 75 mΩ | | 3.5 mm | 2,000 |
| | GW209F | 160 mF | 55 mΩ | 28.5 x 17.0 | 2.1 mm | 300 |
| | GW201F | 400 mF | 55 mΩ | | 2.7 mm | 300 |
| | GW203F | 520 mF | 40 mΩ | 39.0 x 17.0 | 3.4 mm | 2,000 |
| | GS203F | 270 mF | 35 mΩ | | 2.1 mm | 2,000 |
| | GS206F | 680 mF | 35 mΩ | | 2.7 mm | 2,000 |
| | GS208F | 900 mF | 25 mΩ | | 3.4 mm | 2,000 |
| | GS230F | 1200 mF | 25 mΩ | | 3.9 mm | 200 |

| Single cell devices | | | | | | |
|---|---------------------------|--|---|-------------------|---------------------------------|------------------------|
| Voltage & Temperature | Product Name ¹ | CAP ² (± 20%) ³ | ESR ² (max = Nom +20%) ³ | Body Size (mm) | Thickness ⁴ (max) | Minimum Order Quantity |
| 2.5V _{nominal} 2.75V _{peak} -40°C to +70°C T _{max} = 70°C | GZ115F | 180 mF | 55 mΩ | 20.0 x 15.0 | 1.2mm | TBA |
| | GA109F | 170 mF | 50 mΩ | 20.0 x 18.0 | 1.0 mm | 3,000 |
| | GA130F | 800 mF | 40 mΩ | | 1.7mm | 3,000 |
| | GW109F | 320 mF | 30 mΩ | 28.5 x 17.0 | 1.0 mm | 3,000 |
| | GW101F | 800mF | 30 mΩ | | 1.3 mm | 3,000 |
| | GW103F | 1040 mF | 20 mΩ | | 1.7 mm | 3,000 |
| | GS103F | 540 mF | 20 mΩ | 39.0 x 17.0 | 1.0 mm | 3,000 |
| | GS106F | 1360mF | 20 mΩ | | 1.3 mm | 3,000 |
| | GS108F | 1800mF | 15 mΩ | | 1.7 mm | 3,000 |
| | GS130F | 2400 mF | 15 mΩ | | 1.9 mm | 3,000 |

| Parameter | Name | Condition | Minimum | Nominal | Maximum |
|------------------------------|-------------------|----------------------------|----------------|--------------|-----------------|
| Leakage Current ⁵ | I _L | 23°C | | 1μA/F (cell) | 2μA/F (cell) |
| RMS Current | I _{RMS} | 23°C | | | 4A – 8A |
| Pulse Current ⁶ | I _{peak} | | | | 30A |
| ESR change with Temperature | | Min @ +70°C Max @ -40°C | 75% of nominal | | 200% of nominal |

Notes

- Select products are available ex-stock (Standard products). The remainder are available to order.
- Capacitance will decline and ESR will rise over time, at a rate which depends on temperature and voltage. Continuous operation at high temperature & voltage is not recommended. See Section 6 for more information on ageing and endurance.
- DC capacitance and ESR tolerance are measured at 23°C. Max ESR = Nominal ESR +20%.
- Thickness is measured between two parallel plates with 140gm force applied.
- Leakage current is measured after charging to nominal voltage for 120hrs at 23°C.
- Single pulse, non-repetitive current (positive & negative terminal short-circuited).

5. H Series Product Specifications

| Dual cell modules (2 cells connected in series) | | | | | | |
|---|---------------------------|--|---|-------------------|---------------------------------|------------------------|
| Voltage & Temperature | Product Name ¹ | CAP ² (± 20%) ³ | ESR ² (max =Nom +20%) ³ | Body Size (mm) | Thickness ⁴ (max) | Minimum Order Quantity |
| 5.5V _{nominal} 5.8V _{peak} -40°C to +70°C T _{max} = 85°C ⁵ | HA202F | 120 mF | 120 mΩ | 20.0 x 18.0 | 2.5 mm | 2,000 |
| | HA230F | 400 mF | 130 mΩ | | 3.5 mm | 500 |
| | HW209F | 150 mF | 100 mΩ | 28.5 x 17.0 | 2.1 mm | 2,000 |
| | HW201F | 380 mF | 100 mΩ | | 2.7 mm | 2,000 |
| | HW203F | 500 mF | 75 mΩ | | 3.4 mm | 2,000 |
| | HS203F | 250 mF | 55 mΩ | 39.0 x 17.0 | 2.1 mm | 2,000 |
| | HS206F | 650 mF | 55 mΩ | | 2.7 mm | 200 |
| | HS208F | 900 mF | 45 mΩ | | 3.4 mm | 2,000 |
| HS230F | 1200 mF | 45 mΩ | 3.9 mm | | 200 | |

| Single cell devices | | | | | | |
|--|---------------------------|--|--|-------------------|---------------------------------|------------------------|
| Voltage & Temperature | Product Name ¹ | CAP ² (± 20%) ³ | ESR ² (max Nom +20%) ³ | Body Size (mm) | Thickness ⁴ (max) | Minimum Order Quantity |
| 2.75V _{nominal} 2.9V _{peak} -40°C to +70°C T _{max} = 85°C ⁵ | HZ102F | 170 mF | 90 mΩ | 20.0 x 15.0 | 1.2 mm | TBA |
| | HA102F | 240 mF | 60 mΩ | 20.0 x 18.0 | 1.2 mm | 3,000 |
| | HA130F | 800 mF | 65 mΩ | | 1.7 mm | 3,000 |
| | HW109F | 300 mF | 50 mΩ | 28.5 x 17.0 | 1.0 mm | 3,000 |
| | HW101F | 760 mF | 50 mΩ | | 1.3 mm | 3,000 |
| | HW103F | 1000 mF | 40 mΩ | | 1.7 mm | 3,000 |
| | HS103F | 500 mF | 30 mΩ | 39.0 x 17.0 | 1.0 mm | 3,000 |
| | HS106F | 1300 mF | 30 mΩ | | 1.3 mm | 3,000 |
| | HS108F | 1800 mF | 25 mΩ | | 1.7 mm | 3,000 |
| | HS130F | 2400 mF | 25 mΩ | | 1.9 mm | 3,000 |

| Parameter | Name | Condition | Minimum | Nominal | Maximum |
|------------------------------|-------------------|----------------------------|----------------|------------|-----------------|
| Leakage Current ⁶ | I _L | 23°C | | 1μA / cell | 2μA / cell |
| RMS Current | I _{RMS} | 23°C | | | 3A – 6.5A |
| Pulse Current ⁷ | I _{peak} | | | | 30A |
| ESR change with Temperature | | Min @ +70°C Max @ -40°C | 75% of nominal | | 250% of nominal |

Notes

- Select products are available ex-stock (Standard products). The remainder are available to order.
- Capacitance will decline and ESR will rise over time, at a rate which depends on temperature and voltage. Continuous operation at high temperature & voltage is not recommended. See Section 6 for more information on ageing and endurance.
- DC capacitance and ESR tolerance are measured at 23°C. Max ESR = Nominal ESR +20%.
- Thickness is measured between two parallel plates with 140gm force applied.
- Max continuous operating temp = +70°C but can withstand excursions to +85°C
- Leakage current is measured after charging to nominal voltage for 120hrs at 23°C.
- Single pulse, non-repetitive current (positive & negative terminal short-circuited).

6. Storage & Operation Metrics

| Parameter | Condition | Metric | G Series | H Series | Notes |
|---|--|-------------------------------------|----------------|----------------|---|
| Operating temperature | Maximum operating temperature | T_{max} (°C) | 70°C | 85°C | Brief excursions to T_{max} will not damage the device. |
| | Recommended operating temperature range | T_{cont} (°C) | -40°C to +70°C | -40°C to +70°C | Continuous operation at T_{max} is not recommended. |
| Shelf life | Recommended storage temperature & humidity | T_{shelf} (°C) | 23°C | 23°C | CAP-XX recommends storing supercapacitors in their original packaging in an air conditioned room. |
| | | RH_{shelf} (%) | 45% | 45% | |
| | 2 years @ T_{shelf} (17,500 hrs @ 23°C) | C loss (% of initial C) | < 5% | < 10% | |
| | | ESR rise (% of initial ESR) | < 10% | < 20% | |
| | Maximum recommended continuous storage temperature & humidity | $T_{shelfmax}$ (°C) | 35°C | 35°C | CAP-XX supercapacitors can be stored at any temperature not exceeding their maximum operating temperature (T_{max}), but storage at continuous high temperature and humidity is not recommended, and will cause premature ageing. |
| | | $RH_{shelfmax}$ (%) | 65% | 65% | |
| 2 years @ $T_{shelfmax}$ (17,500 hrs @ 35°C) | C loss (% of initial C) | < 10% | < 20% | | |
| | ESR rise (% of initial ESR) | < 20% | < 40% | | |
| Cycle life | 500,000 cycles @ 23°C ($V_n \rightarrow \frac{1}{2}V_n$, $I = 0.5A$) | C loss (% of initial C) | < 1% | < 5% | Voltage cycling at low RMS current will not affect life. |
| | | ESR rise (% of initial ESR) | < 1% | < 5% | Cycling at high RMS current will cause self-heating, which will increase ageing rates. |
| Load life | @ V_n & 23°C G series = 5.0V, 23°C H Series = 5.5V, 23°C | C loss rate (% / 1000hr) | < 1% | < 3% | Note that C loss rates & ESR rise rates are not calculated or extrapolated from 1,000 hr data. |
| | | ESR rise rate (% of initial/1000hr) | < 1% | < 3% | |
| | @ 80% V_n & 80% T_{cont} G series = 4.0V, 50°C H Series = 4.5V, 50°C | C loss rate (% / 1000hr) | < 2% | < 6% | They are measured during long term life tests over periods at least 12 months. |
| | | ESR rise rate (% of initial/1000hr) | < 4% | < 9% | |
| | @ V_n & T_{cont} G series = 5.0V, 70°C H Series = 5.5V, 70°C | C loss rate (% / 1000hr) | < 10% | < 20% | ESR rise rate is linear. C loss follows an exponential decay. |
| | | ESR rise rate (% of initial/1000hr) | < 30% | < 30% | |
| MTTF | @ V_n & 23°C G series = 5.0V, 23°C H Series = 5.5V, 23°C | MTTF (years) | > 10 | > 10 | MTTF is calculated with a regression equation (Arrhenius form) from observed failures during long term life testing. Note that such calculations are inaccurate at low temperatures due to low/no observed failures. |
| | @ 80% V_n & 80% T_{cont} G series = 4.0V, 50°C H Series = 4.5V, 50°C | MTTF (years) | ~2 | ~2 | |
| | @ V_n & T_{cont} G series = 5.0V, 70°C H Series = 5.5V, 70°C | MTTF (years) | < 1 | < 1 | |

7. Energy & Power Density

| Parameter | Description | Metric | G Series | H Series | Notes |
|---------------------------|---|-------------------------------------|----------------------|---|--|
| Energy | Full discharge from nominal voltage (V_n) | Capacity (mAh) | 0.1 - 1.7 | 0.2 - 1.8 | Capacity = $(C \times V_n) / 3.6$ |
| | Gravimetric Energy Density | E_{grav} (Joules/kg) | 1,554 – 6,857 | 1,927 – 8,372 | $E_{grav} = (\frac{1}{2}C \times V^2) / \text{Weight}$ |
| | | E_{grav} (Wh/kg) | 0.4 - 1.9 | 0.5 – 2.3 | $E_{grav} = (\frac{1}{2}C \times V^2) / (3600 \times \text{Weight})$ |
| Volumetric Energy Density | E_{vol} (Wh/L) | 0.5 - 1.6 | 0.6 – 1.9 | $E_{vol} = (\frac{1}{2}C \times V^2) / (3600 \times \text{Volume})$ | |
| Power | Gravimetric Power Density | P_{grav} (kW/kg) | 83 - 121 | 60 – 85 | $P_{grav} = V_n^2 / (4xESR) / \text{Weight}$ |
| | Volumetric Power Density | P_{vol} (kW/L) | 87 - 128 | 58 – 99 | $P_{vol} = V_n^2 / (4xESR) / \text{Volume}$ |

8. Product Names

CAP-XX products have a 6 character alpha-numeric product name in the form "GS230F". See the table below for information provided in the product name.

Note that only the first 5 characters of the product name are printed on the device.

| Position | Code | Meaning | Description |
|----------|-------------|---------------|--|
| 1 | G H | Series code | <p>"G" series are General purpose supercapacitors:</p> <ul style="list-style-type: none"> Operating temperature range: -40°C to +70°C Continuous load voltage: 2.5V / 5.0V <p>"H" series are High temperature/High voltage supercapacitors:</p> <ul style="list-style-type: none"> Operating temperature range: -40°C to +85°C Continuous load voltage: 2.75V / 5.5V |
| 2 | S W A | Package code | <p>"S" products are 39 x 17mm, excluding the terminals. "W" products are 28.5 x 17mm, excluding the terminals. "A" products are 20 x 18mm, including the terminals.</p> <p>Refer to the Section 20 for detailed information on body sizes, terminal projections and PCB layout measurements.</p> |
| 3 | 1 2 | Cell code | <p>"1" denotes a single cell supercapacitor. "2" denotes a dual cell supercapacitor, comprising two single cells connected in series.</p> |
| 4, 5 | Nn | Product code | An internal CAP-XX reference to denote the cell configuration. |
| 6 | F G | Mounting code | <p>"F" suffix (e.g. GS230F) indicates no adhesive tape on the underside of the device (standard configuration).</p> <p>"G" suffix (e.g. GS230G) indicates double-sided, insulating adhesive tape on the underside of the device. This option is available to order on all CAP-XX parts, and can assist with mounting, electrical isolation and extreme shock and vibration.</p> |

9. Product Markings

All CAP-XX products are marked with the Product Name, Batch Code, Capacitance, continuous operating Voltage, and the Positive terminal location. Some products also show the Device Number, ESR and Country of Manufacture. Dual cell modules show the Balance (mid-point) terminal location.

"S" & "W" Dual Cells

Front:



Back ("F" part):
(Standard)



Back ("G" part, with mounting tape)
(Special Order)

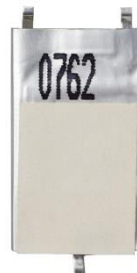

"S" & "W" Single Cells

Front:



Back ("F" part):



"A" Dual Cells

Front:



Back ("F" part):



"A" Single Cells

Front:



Back ("F" part):





Batch Codes Transport & Storage

10. Batch Codes

“S”, “W” & “A” series devices

S, W & A products have a 6 character alpha-numeric Batch Code of the form "N2CAJ2", where:

- Position 1 = Manufacturing site code
- Position 2 = Manufacturing line number
- Position 3 = Year of manufacture
- Position 4 = Month of manufacture
- Position 5 = Day of manufacture
- Position 6 = Batch number that day on the specified line

The characters at Positions 3 - 6 indicate a number according to the following sequence:

| | | | | | | | | | | | | | | | | |
|------------------|----------|----------|----------|----------|----------|----------|----------|----------|----------|----------|----------|----------|----------|----------|----------|----------|
| Character | 1 | 2 | 3 | 4 | 5 | 6 | 7 | 8 | 9 | A | B | C | D | E | F | G |
| Number | 1 | 2 | 3 | 4 | 5 | 6 | 7 | 8 | 9 | 10 | 11 | 12 | 13 | 14 | 15 | 16 |
| Character | H | I | J | K | L | M | N | O | P | Q | R | S | T | U | V | |
| Number | 17 | 18 | 19 | 20 | 21 | 22 | 23 | 24 | 25 | 26 | 27 | 28 | 29 | 30 | 31 | |

11. Transportation & Storage

IATA Dangerous Goods Regulations

Supercapacitors with an energy storage capacity of < 0.3Wh are not subject to any transportation restrictions (see IATA Dangerous Goods Regulations, 54th Edition, UN3499 in Class 9, Electrical Double-Layer Capacitors, ELDC).

All CAP-XX supercapacitors have an energy storage capacity < 0.3Wh (1,080J), and are therefore not subject to any transportation restrictions.

Storage Conditions

CAP-XX supercapacitors and assembled devices containing CAP-XX supercapacitors may be stored at temperatures of up to 70°C, but for maximum life, CAP-XX recommends storage in the original packaging, in an air conditioned room at ~23°C.

Avoid humid, acidic or alkaline storage environments and excessive external forces.

12. Packaging & Package Quantities

CAP-XX supercapacitors are shipped in stackable, anti-static trays.

Each tray holds 20 to 50 devices (depending on the body size), in cavities moulded into the tray.

The trays are designed to protect the devices during transportation, and to facilitate their removal by hand or vacuum pen prior to assembly.

Packaging for Shipment

The Minimum Package Quantity (MPQ) is a stack of 10 product trays and a cover tray. This package is then wrapped in plastic bubble wrap or sealed in a moisture resistant foil bag.

Each package contains 200 ("S" series devices), 300 ("W" series devices), or 500 pieces ("A" series devices). This is the MPQ, and also the MOQ for wholesale purchase.

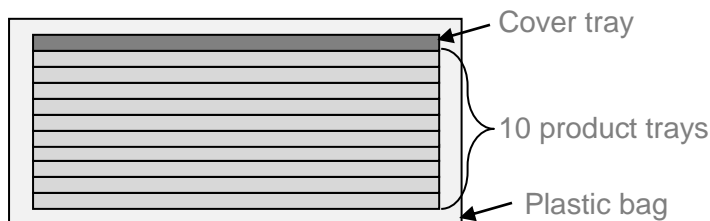

Packing Tray for "S" series devices

20 pieces / Tray

Package Quantity = 200pcs

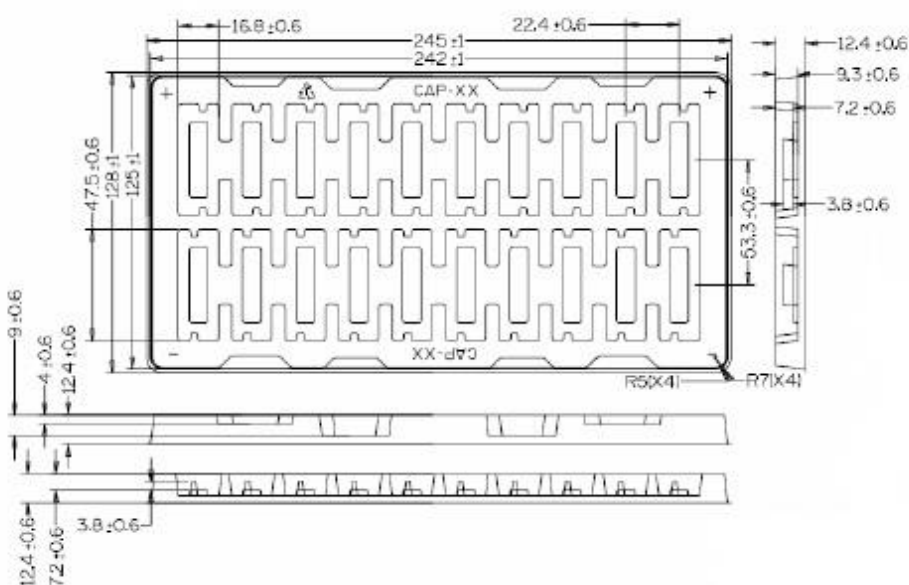

Packing Tray for "W" series devices

30 pieces / Tray

Package Quantity = 300pcs

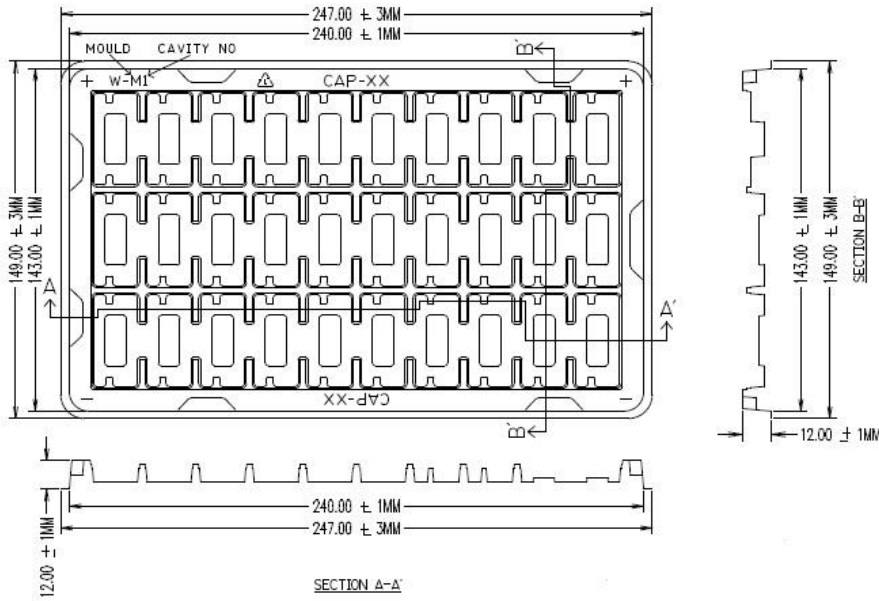

Packing Tray for "A" series devices

50 pieces / Tray

Package Quantity = 500pcs

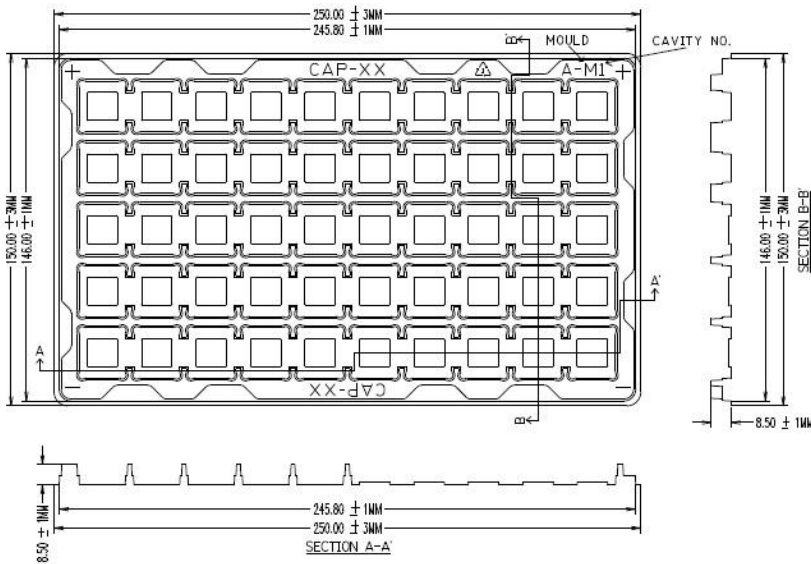

PETE



LDPE

CAP-XX uses sustainable packaging. All our packaging material are recyclable. The clear product trays are made from PET. ESD safe bubble wraps are made from LDPE. The shipping boxes are corrugated cardboard. Please ensure all packaging is disposed in accordance with the relevant recycling procedures of the region where CAP-XX products are used.

13. Cautions Before Use

CAP-XX supercapacitors are “burned in” during production, and have a defined polarity, as shown by the positive terminal marked on the face of the product. Reversing the polarity of the device will not damage the device, but may cause a rise in the ESR and will void the warranty. Please verify the orientation of the supercapacitor in accordance with the product markings before assembly.

CAP-XX supercapacitors are heat-sensitive. Over-heating of the supercapacitor may result in a degradation of performance and useful life (see Section 17 for more information).

CAP-XX supercapacitors must only be used within their rated voltage range. Over-voltage may cause swelling and eventually, product failure.

Dual cell supercapacitor modules contain two cells connected in series. Please ensure that the voltage in both cells remains below the rated peak and constant operating voltages. CAP-XX recommends the use of an active balancing circuit or passive balancing resistors to prevent an over-voltage situation developing in one cell. Contact CAP-XX for more information on cell balancing.

CAP-XX supercapacitors are fully discharged when shipped. Devices should be handled and soldered in a discharged state.

14. Soldering & Assembly

Placement

Avoid contact between conductive areas on the underside of the supercapacitor and vias, through holes or tracks on the PCB. Refer to the Product Drawings in Section 20 for detailed information on the location and size of these conductive areas, and the recommended positioning and size of PCB landing pads.

Do not apply excessive force to the supercapacitor during placement. CAP-XX supercapacitors should not be exposed to more than 400kPa pressure across the flat surface of the device (equivalent to a weight of 10kg). Bending or applying too much pressure to the device may damage the seals, resulting in device failure.

CAP-XX supercapacitor terminals are manufactured from tinned (pure bright tin), annealed (low temper) copper that is pliable. Care should be taken to avoid bending the terminals.

To mount the supercapacitor on the PCB, remove the device from the tray by hand, with a vacuum pen, or by an automated pick and place robotic arm with a vacuum pen, and locate onto the PCB.

CAP-XX offers an adhesive insulating tape on the underside of the device as an option to assist in mounting. The PCB surface should be clean and free from oil, grease or flux residue prior to mounting. Remove the release tape, position the device carefully and press firmly into place. An extended hold time is not required.

Soldering

CAP-XX supercapacitors are designed for direct soldering onto the PCB. Soldering the terminals to the PCB will ensure the highest contact reliability and lowest contact resistance. Do NOT solder directly to the device casing. This will cause permanent internal damage to the supercapacitor.

CAP-XX supercapacitors are NOT SUITABLE for infrared reflow soldering, hot-air reflow soldering, or wave soldering. They should be mounted as a secondary operation, using a manual soldering iron, a hot bar soldering jig, conductive adhesive, ultrasonic welding or laser welding.

CAP-XX recommends the use of a water-soluble flux, or a no-clean (low residue) flux, and low temperature solder compounds.

Soldering should be undertaken with a low wattage soldering iron (<70 W), applying heat just long enough to achieve a good connection. The maximum recommended soldering time is 5 seconds, when using an iron at 400°C in an ambient temperature of 23°C.

Capacitor Internal Temperature when Soldering

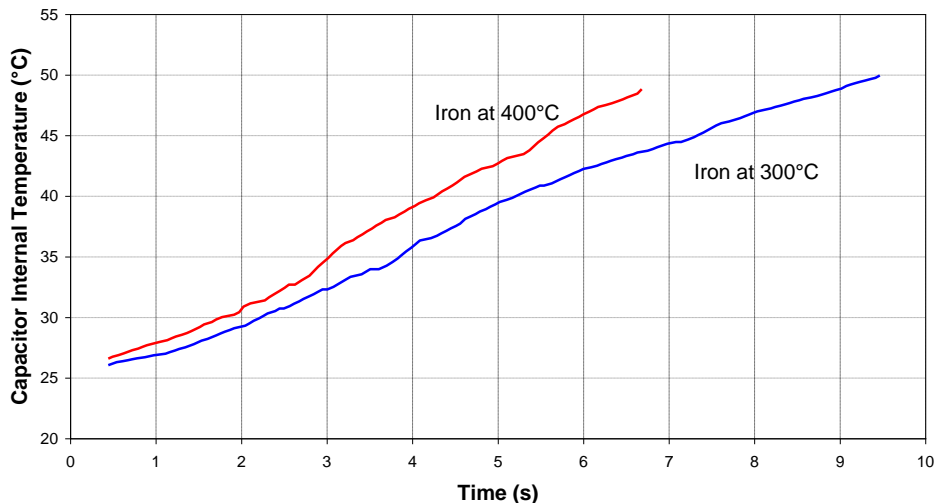

If a hot-air gun is used to reflow the solder during a re-mount or de-mount, care must be taken to prevent excessive heating of the package adjacent to the solder terminals. Allow at least 15 sec between successive soldering attempts for the device to cool down.

Washing

CAP-XX supercapacitors are NOT SUITABLE for solvent-based washing. Do not use any solvent cleaners such as acetone, benzene, isopropyl alcohol or halogenated solvents.

CAP-XX recommends that the assembly be washed with an aqueous cleaning solution based on de-ionized water to remove any flux residue. Do not wash at temperatures exceeding 70°C, or at spray pressures exceeding 50psi. The supercapacitor may be fully submerged briefly during the washing process, but exposure times to water should be minimized.

Drying

Rapid airflow around the device during drying will assist in the removal of any residual moisture trapped in the package. Keep drying times to the minimum necessary, at temperatures not exceeding 70°C.

Conformal Coatings & Potting

Some applications require the use of conformal coatings or “potting” compounds in order to meet specific performance requirements, such as enhanced shock and vibration resistance, waterproofing, protection from corrosive environments, and ATEX / Intrinsic Safety certifications.

Potting may involve the use of thermo-setting plastics, silicone rubber gels, or polyurethane, whilst conformal coatings generally involve acrylics, epoxies, polyurethane, silicones, Parylene, or amorphous fluoro polymers. In all cases, care must be taken to ensure that the device is not subjected to temperatures outside the specified range during setting and curing, and that solvents used in the process will not damage the external packaging of the supercapacitor. Contact CAP-XX for more information if required.

15. Safety

CAP-XX supercapacitors are very safe and reliable.

Failure modes

The failure mode for a supercapacitor is usually open circuit, with ESR rising to infinity.

This can occur if the device is exposed to high temperature or voltage or as a result of electrolyte loss over time. These situations can occur as a result of assembly errors (e.g. over-heating the device during soldering), circuit design errors (e.g. failure to balance the cell voltages in a dual cell device correctly), environmental extremes (e.g. temperature excursions beyond the specified range or duration), or natural ageing (e.g. permeation of the electrolyte solvent through the package seal).

Occasionally, supercapacitors will fail as a short circuit. This can be due to physical damage sustained during handling or assembly (e.g. if the package is pierced by a sharp, conductive object), assembly errors (e.g. by shorting a terminal to the package during soldering), circuit design errors (e.g. by running vias on the PCB under conductive areas on the package), industrial design errors (e.g. by exerting excessive pressure on the device, damaging the internal separator membrane), or by manufacturing errors (e.g. by misalignment of the separator between electrodes).

Resistance to Shock

CAP-XX has undertaken tests in accordance with IEC68-2-27 to determine the effects of repeated shocks on both the mechanical integrity and electrical performance of its supercapacitors:

- Pulse Shape Half-Sine
- Amplitude 30g \pm 20%
- Duration 18ms \pm 5%
- No. of Shocks 3 in each direction (18 in total)
- No. of Axes 3, orthogonal

Results: final C \geq 80% of initial, final ESR \leq 120% of initial, final thickness within specification

Note: To achieve the highest levels of resistance to shock, CAP-XX recommends the use of an adhesive mounting tape on the underside of the device. Order the "G" option, e.g. GW201G for this tape which adds 0.1mm to the device thickness – see section 20, Product Drawings.

Resistance to Vibration

CAP-XX has undertaken tests in accordance with IEC60065-2-6 to determine the effects of sustained vibration on both the mechanical integrity and electrical performance of its supercapacitors:

- Type Sinusoidal
- Frequency 10Hz - 500Hz
- Amplitude 0.75 mm or acceleration: 100 m/s² (whichever is less stringent)
- Sweep Rate 1 Octave/min
- No. of Cycles 10 (10Hz - 500Hz - 10Hz)
- No. of Axes 3, orthogonal

Results: final C \geq 80% of initial, final ESR \leq 120% of initial, final thickness within specification

Note: To achieve the highest levels of resistance to vibration, CAP-XX recommends the use an adhesive mounting tape on the underside of the device, "G" option.

Drop-Test

CAP-XX has undertaken tests to determine the effects of repeated drops on both the mechanical integrity and electrical performance of its supercapacitors:

- Mounting Mount the supercapacitor in a test jig as set out below

- Method Drop the test jig onto a concrete floor from a height of 2m
- No. of Cycles 3 drops, one on each axis

Results: No electrical or mechanical degradation observed when following the mounting rules.

Mounting during drop test:

- Constrained by the device housing, with a maximum clearance of 1mm – The supercapacitor was connected to the PCB only by the solder connections on the terminals.
- Unconstrained by the device housing - The supercapacitor was connected to the PCB with double-sided adhesive tape and by solder connections on all terminals.

For maximum product performance in harsh environments, CAP-XX recommends the use of an adhesive mounting tape on the underside of the device, “G” option, or a conformal coating/potting compound.

Exposure to an Open Flame

A fully charged supercapacitor was burned with an alcohol lamp.

Results: The supercapacitor expands due to the heat, and the seal weakens, but does not burst. There is no ignition, no fire, and no scattering of pieces and/or sparks.



Exposure to Heat

A fully charged supercapacitor was placed in an oven for 1hr at 130°C.

Results: The supercapacitor expands due to the heat, and the seal weakens, but does not burst. There is no smoke, no fire, and no gas emission.



Pressure

A fully charged supercapacitor was pressed with a 10mm diameter pole, to 2/3 of its initial thickness.

Results: The supercapacitor loses its charge. There is no ignition, no smoke, no fire, no gas emission, and no scattering of pieces and/or sparks.



Puncture

A fully charged supercapacitor was punctured with a 2mm diameter steel needle.

Results: The supercapacitor loses its charge. There is no ignition, no smoke, no fire, no gas emission, and no scattering of pieces and/or sparks.

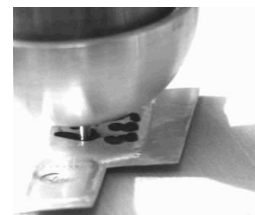

16. Dimensional Stability & Low Pressure Environments

CAP-XX supercapacitors are hermetically sealed, and contain a very small amount of a liquid electrolyte. At high altitudes (with low external pressure), the device may swell and ESR may increase. Please contact CAP-XX for more information on use in low pressure environments.

The aluminium soft pack will swell at high temperature, and may exert force on adjacent components. If unconstrained, a device may swell by up to 50% of its nominal thickness at 70°C.

If constrained by the product case or adjacent components, the supercapacitor may exert up to 7N of force on its surroundings at 70°C. As an example, with a contact surface area of 1.7cm², a dual cell W device will exert a pressure of ~42kPa (6psi) on a fixed surface at 70°C.

17. Response to Over-Temperature Events

CAP-XX supercapacitors are heat-sensitive. Over-heating of the supercapacitor may result in a degradation of performance and useful life. Note that the thermal mass of CAP-XX supercapacitors is very small, so the temperature of the device will equalize to its environment very quickly.

G series devices are rated to a maximum temperature of 70°C, whilst the H series is rated to 85°C. CAP-XX does not recommend operating supercapacitors at or near their maximum temperature rating constantly, as they will age rapidly (i.e. ESR will rise and capacitance will fall).

Exceeding the rated maximum temperature will cause even more accelerated ageing and may cause immediate failure depending on the temperature reached and the time exposed.

At temperatures between 85°C and 100°C, there will be a progressive change in the dimensions of the package (puffing). Usually, this is reversible, and electrical performance is retained. As the temperature approaches 100°C, the probability of non-reversible change increases. This will occasionally cause immediate failure, and degraded electrical performance due to physical damage to the internal structure of the device.

At temperatures greater than 100°C, electrical performance will degrade rapidly, and permanent electrical failure becomes increasingly likely. At 150°C or higher, the seals will melt and the device will fail both physically and electrically.

18. Certifications & Compliances

ISO 9001:2015

CAP-XX is certified as following the ISO 9001 Quality Management System. The current certification can be found by typing "CAP-XX" in the Company field of our certifying organisation, BSI's client directory page <https://www.bsigroup.com/en-AU/Our-services/Certification/client-directory/>.

Underwriter's Laboratory (UL 810A)

CAP-XX H series prismatic products have been tested by Underwriter's Laboratory and are certified as UL-Recognized Components. The CAP-XX certified products can be found by typing "CAP-XX" in the Company Name field on the page database.ul.com and then clicking on the link BBBG2.MH47599.

RoHS

All CAP-XX products are RoHS2 compliant. Substances specified in the European Union directive 2011/65/EU and Chinese Government directive (to standard SJ/T 11363 – 2006) are either not present at all, or are present at levels below those specified in the directive.

An RoHS Certificate of Compliance is available on the [CAP-XX website](#).

Real time RoHS reports on CAP-XX parts can be obtained on [BOMcheck](#).

REACH

All CAP-XX products are REACH compliant.

Pre-registration and registration of substances in articles: CAP-XX does not supply any products that would be considered an article with a substance intended to be released during normal and reasonably foreseeable conditions of use, and therefore has no plans for pre-registration.

Substances of Very High Concern (SVHC): CAP-XX products do not contain any chemicals listed as SVHC in Annex XIV or the Candidate List under Article 57 of European Directive EC 1907/2006 and as amended by subsequent regulations.

Restricted use substances: CAP-XX products either do not contain any of the restricted-use substances given in Annex XVII of European Directive EC 1907/2006 and as amended by subsequent regulations or meet any of the restrictions placed on them.

A REACH Certificate of Compliance is available on the [CAP-XX website](#).

Real time REACH reports on CAP-XX parts can be obtained on [BOMcheck](#).

Rare Earth Metals & Conflict Metals

CAP-XX products do not contain any rare earth metals or conflict metals as defined in Section 1502 of the United States Financial Reform Bill (HR 4173), 2010. Specifically, CAP-XX supercapacitors do not contain any Tantalum (Ta), Tungsten (W) or Gold (Au). CAP-XX products contain Tin (Sn) sourced only from non-conflict sources.

A Certificate of Compliance is available on the [CAP-XX website](#).

The Conflict Materials report can be obtained on [BOMcheck](#).

Halogens

CAP-XX products are halogen-free as defined under the draft IPC/JEDEC J-STD-709 standard for electronic components and assemblies. Specifically, CAP-XX products do not contain any brominated or chlorinated flame retardants (BFRs/CFRs) or PVC plastics.

A Certificate of Compliance is available on the [CAP-XX website](#).

19. Notes & Disclaimers

Product specifications in this document are current as of its publication date. Specifications are subject to change, and products may be discontinued without advance notice.

This document contains limited specification detail. Please refer to the relevant Data Sheet for more complete specification data on specific products, or contact CAP-XX for more information.

CAP-XX products are not authorized for use in medical devices classified as Class III under the European Union Directive 93/42/EC, 2010, or Class D of the Global Harmonization Task Force Guidelines, 2012. Please contact CAP-XX for more information on the use of our products in any applications which may be considered to carry any risk of harm to people or property.

CAP-XX and trade names associated with CAP-XX are protected by Trademark.

Technology referred to in this document is protected by US patent 06631072 and other patents and pending patents.

20. Product Drawings: Mechanical & Electrical

"S" Package Dual Cell Devices

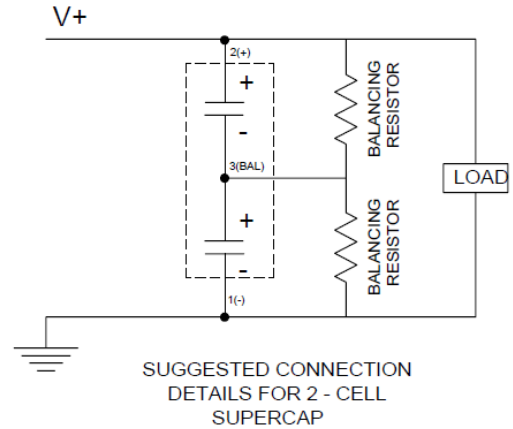
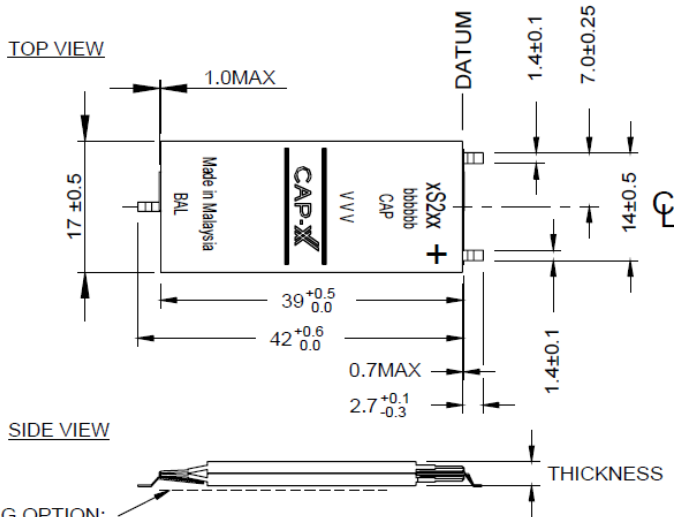

BOTTOM VIEW - F OPTION

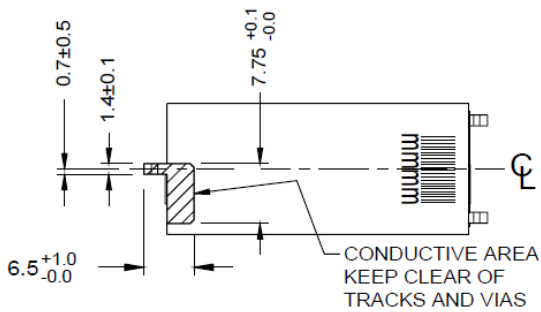

BOTTOM VIEW - G OPTION

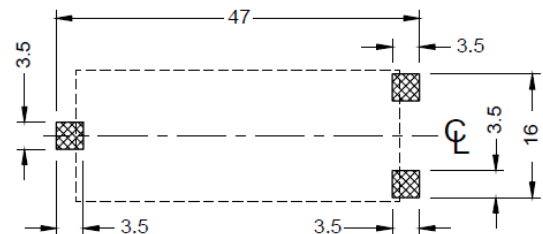
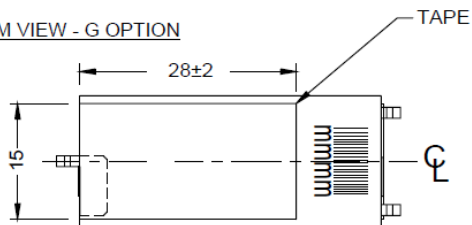

SUGGESTED PAD LAYOUT

CUSTOMERS SHOULD DETERMINE
FINAL PAD SIZE AND PLACEMENT
BASED ON THEIR
MANUFACTURING TOLERANCES

LEGEND

mmmm: DEVICE ID
vvv: DEVICE VOLTAGE
bbbbbb: BATCH ID
cap: CAPACITANCE

"W" Package Dual Cell Devices

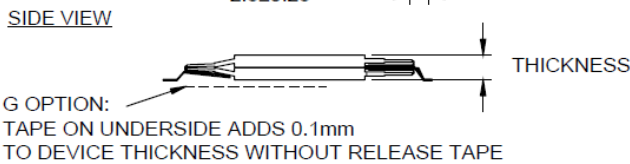
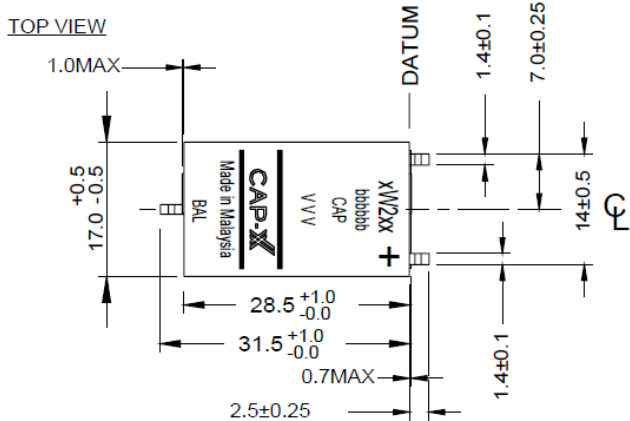

BOTTOM VIEW - F OPTION

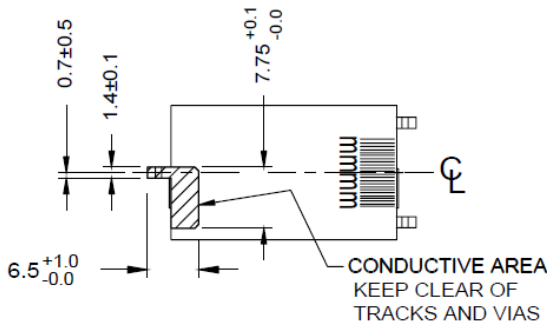

BOTTOM VIEW - G OPTION

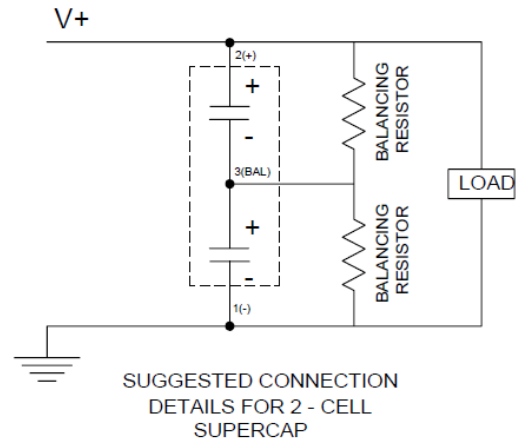
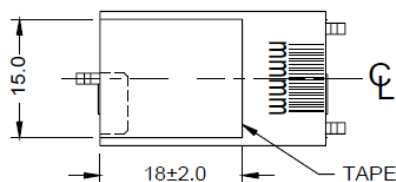

LEGEND

mmmm: DEVICE ID
vvv: DEVICE VOLTAGE
bbbbbb: BATCH ID
cap: CAPACITANCE

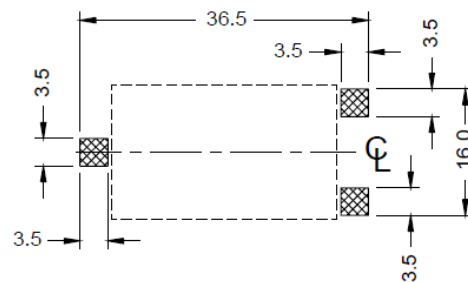

SUGGESTED PAD LAYOUT

CUSTOMERS SHOULD DETERMINE
FINAL PAD SIZE AND PLACEMENT
BASED ON THEIR
MANUFACTURING TOLERANCES

"A" Package Dual Cell Devices

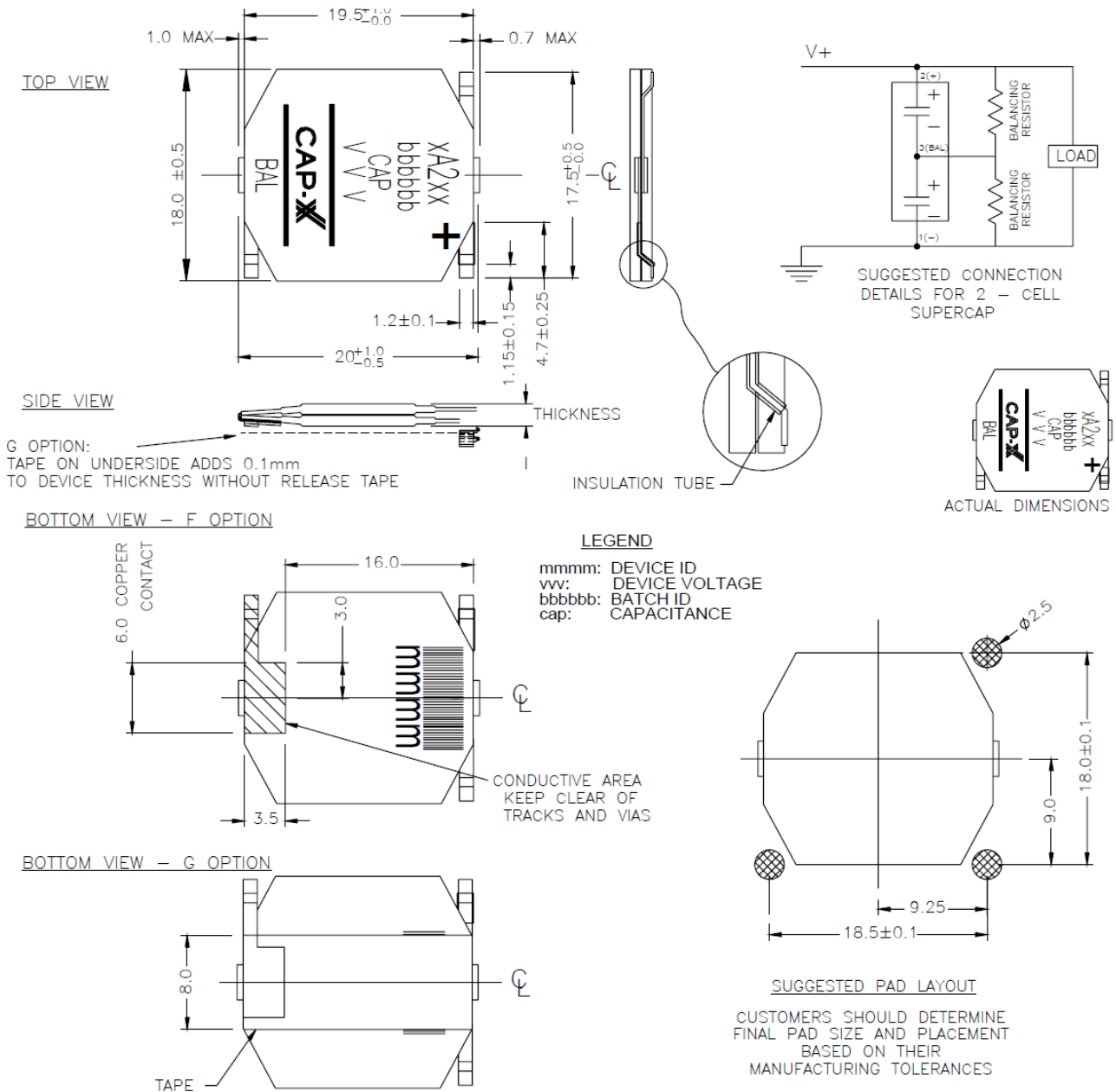

"Z" Package Dual Cell Devices

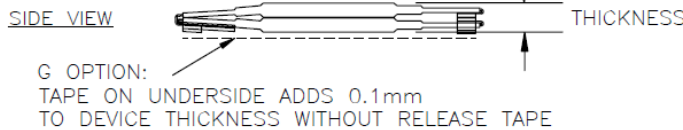
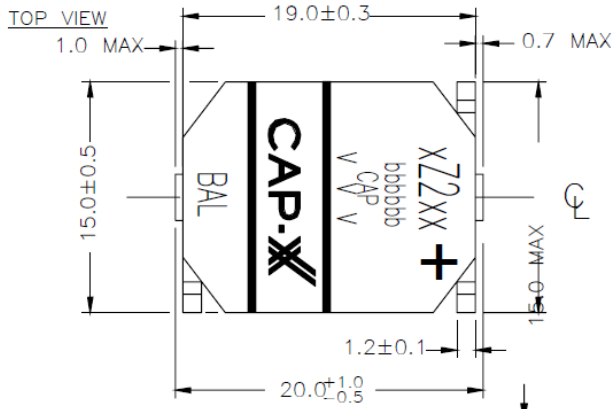

BOTTOM VIEW - F OPTION

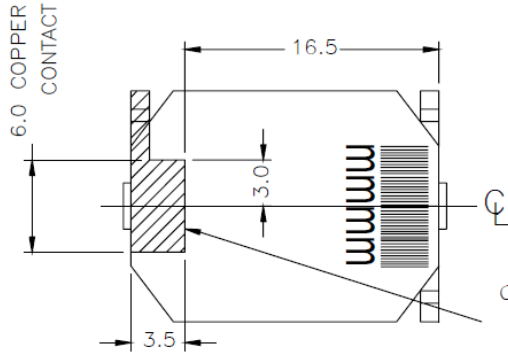

BOTTOM VIEW - G OPTION

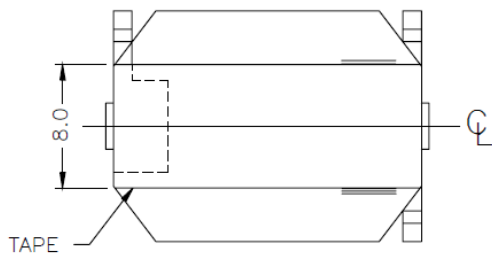

LEGEND

- mmmm: DEVICE ID
- vvv: DEVICE VOLTAGE
- bbbbbb: BATCH ID
- cap: CAPACITANCE

CONDUCTIVE AREA
KEEP CLEAR OF
TRACKS AND VIAS

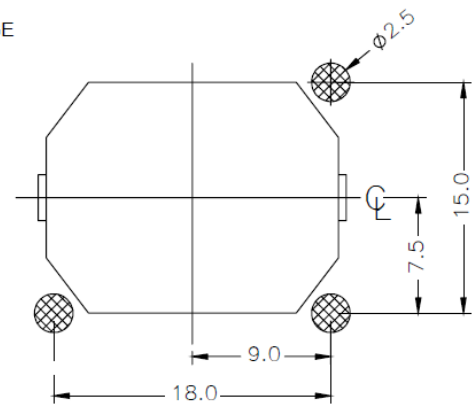
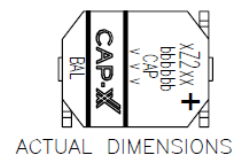
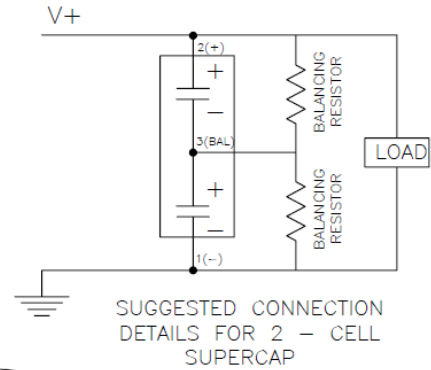

SUGGESTED PAD LAYOUT

CUSTOMERS SHOULD DETERMINE
FINAL PAD SIZE AND PLACEMENT
BASED ON THEIR
MANUFACTURING TOLERANCES

"S" Package Single Cell Supercapacitors

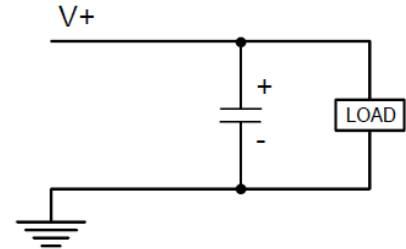
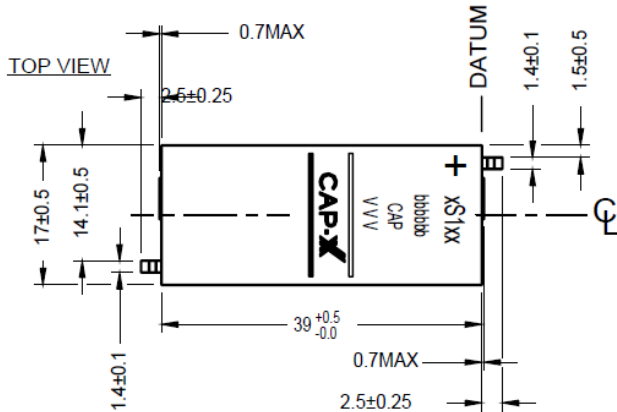

SUGGESTED CONNECTION
DETAILS FOR SINGLE CELL
SUPERCAP

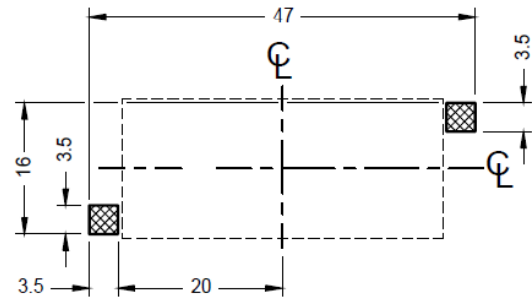
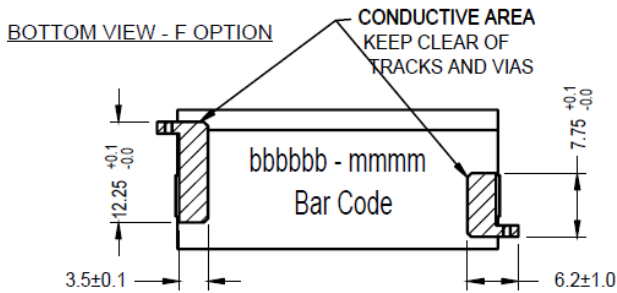
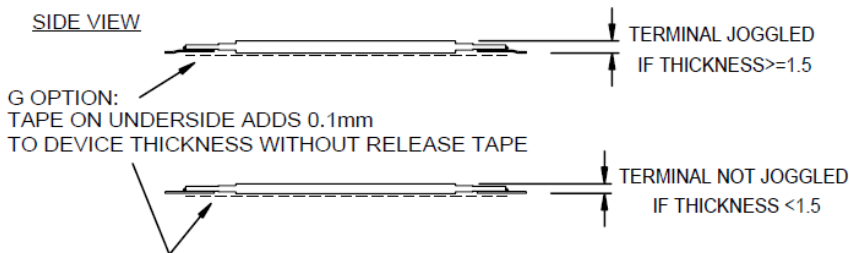

SUGGESTED PAD LAYOUT

CUSTOMERS SHOULD DETERMINE
FINAL PAD SIZE AND PLACEMENT
BASED ON THEIR
MANUFACTURING TOLERANCES

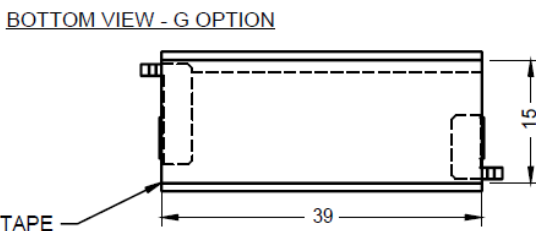

"W" Package Single Cell Supercapacitors

TOP VIEW

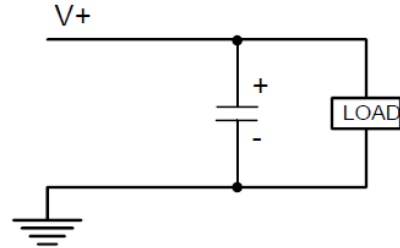
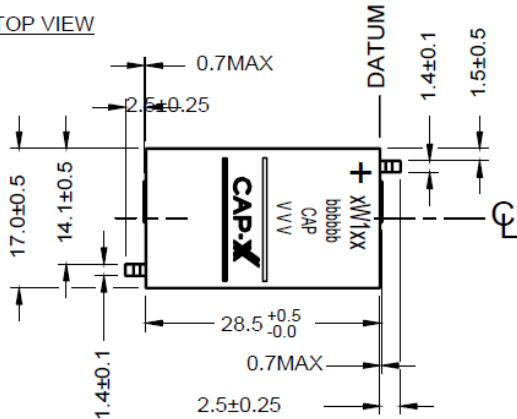

SUGGESTED CONNECTION
DETAILS FOR SINGLE CELL
SUPERCAP

SIDE VIEW

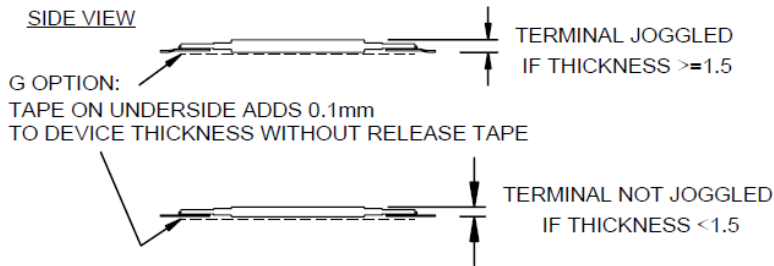

BOTTOM VIEW - F OPTION

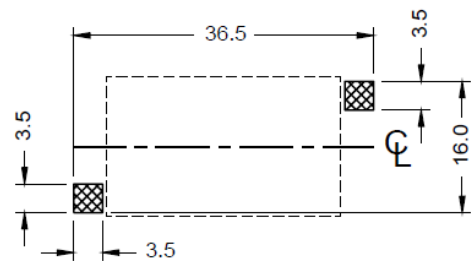
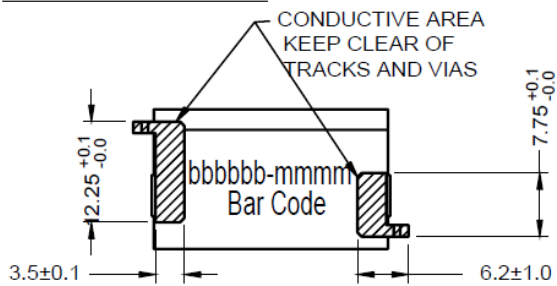

SUGGESTED PAD LAYOUT

CUSTOMERS SHOULD DETERMINE
FINAL PAD SIZE AND PLACEMENT
BASED ON THEIR
MANUFACTURING TOLERANCES

BOTTOM VIEW - G OPTION

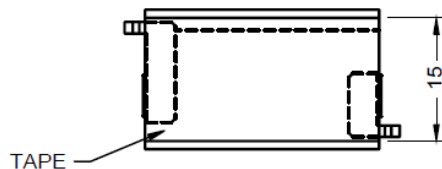

"A" Package Single Cell Supercapacitors

TOP VIEW

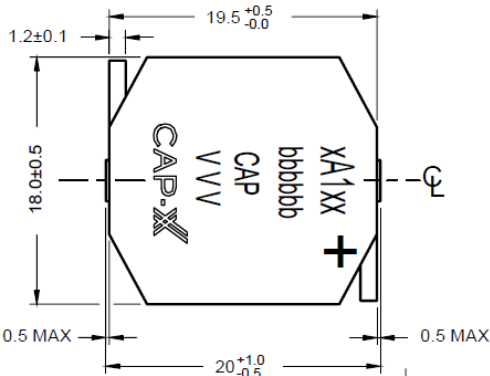

SIDE VIEW

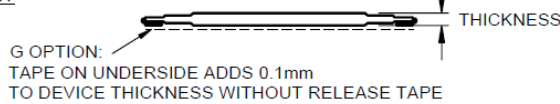

THICKNESS

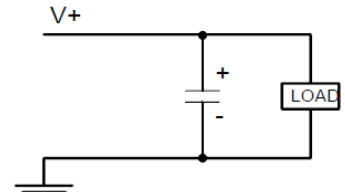
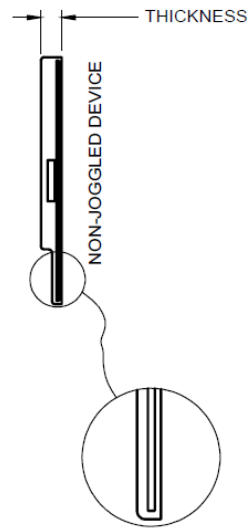

SUGGESTED CONNECTION
DETAILS FOR SINGLE CELL
SUPERCAP

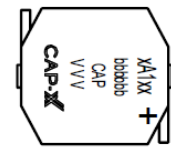

ACTUAL DIMENSIONS

BOTTOM VIEW - F OPTION

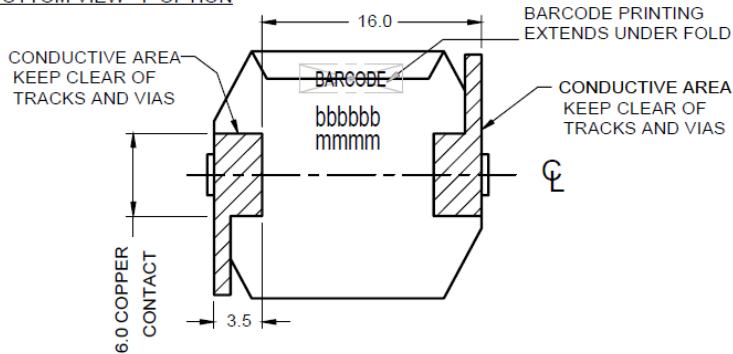

BOTTOM VIEW - G OPTION

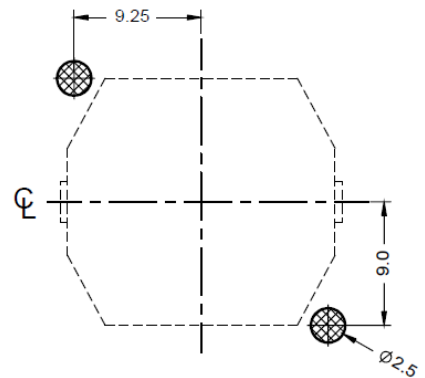
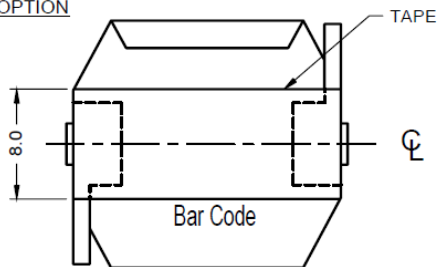

SUGGESTED PAD LAYOUT

CUSTOMERS SHOULD DETERMINE
FINAL PAD SIZE AND PLACEMENT
BASED ON THEIR
MANUFACTURING TOLERANCES

"Z" Package Single Cell Supercapacitors

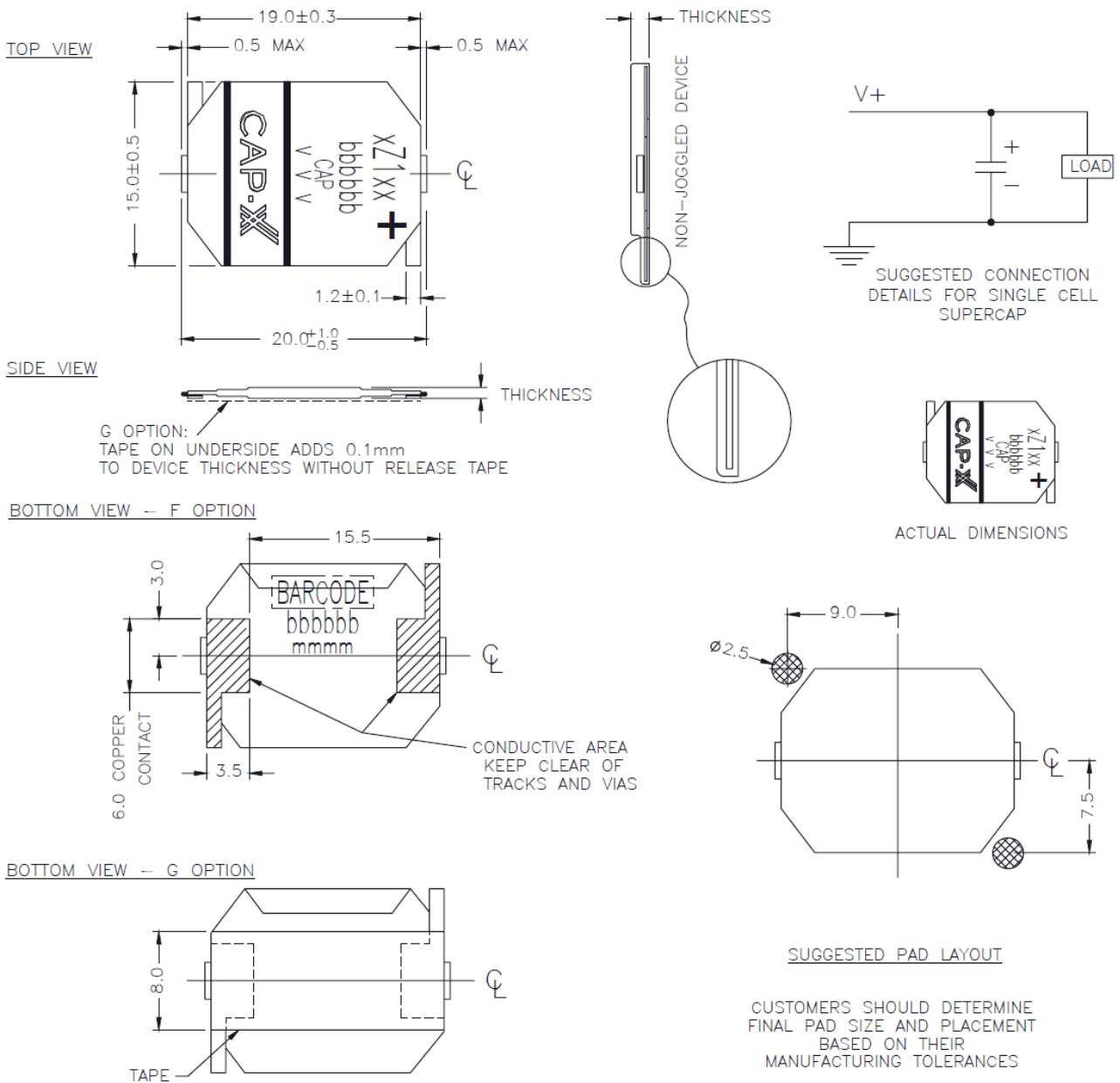



Contact Information

21. Contact Information

Principal Office

CAP-XX (Australia) Pty Ltd
Unit 9, 12 Mars Road
Lane Cove, NSW 2066
Australia

Sales & Product Enquiries

Website:

www.cap-xx.com

Email:

sales@cap-xx.com

Telephone:

+61 2 9420 0690

Distributors

AMERICAS

USA & Canada

Tecate Industries

www.tecategroup.com

ASIA

ASEAN & South Asia
China

McCoy Components
King Horn Enterprises
Xiamen Holder Electronics

www.mccoycomponents.com

www.kinghornhk.com/en/

www.xmholder.com

Japan

Synerdyne

www.syr.co.jp

Korea

Changnam I.N.T

www.changnam.com

Taiwan

PAC Electronics

www.pactw.com.tw

EUROPE

Denmark

ACTE Denmark

www.acte.dk

Finland

ACTE Finland

www.acte.fi

France & Benelux

CATS

www.cats-france.fr

Germany & Switzerland

Unitronic

www.unitronic.de

Norway

ACTE Norway

www.acte.no

Poland & Russia

ACTE Poland

www.acte.pl

Spain & Portugal

ELCO Componentes

www.elcocomponentes.com

Sweden

ACTE Sweden

www.acte.se

UK, Ireland & Spain

A-TEC International

www.a-tecuk.com

UK & Ireland

E-Tech Components UK Ltd

www.etchcomponents.com

MIDDLE EAST & AFRICA

Israel

B. Roman (2001)

www.broman.co.il

South Africa

Seven Labs Technology

www.sevenlabs.co.za